

Model: TS-202

WALKIE TALKIES

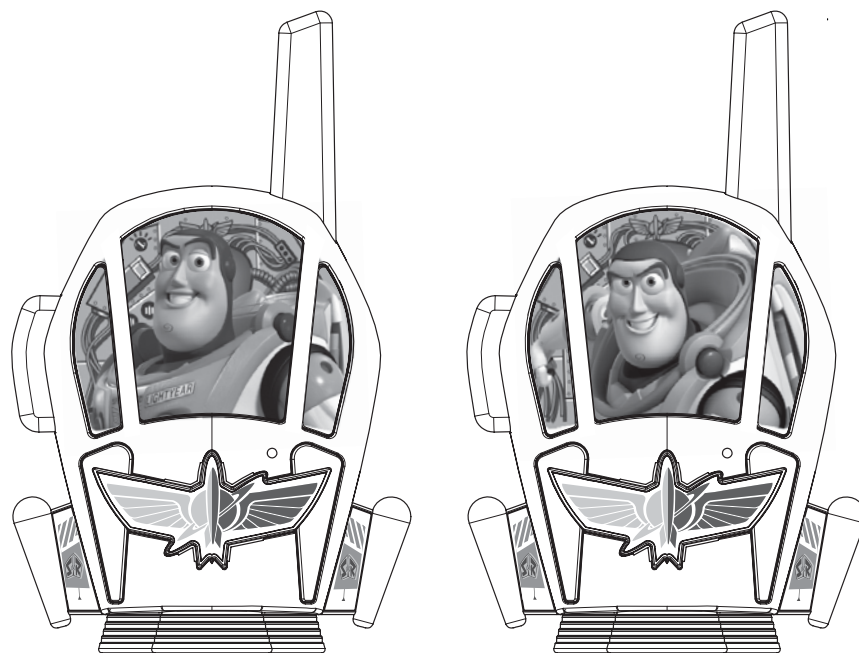

Frequency: 434MHz This product bears the selective sorting symbol for waste electrical and electronic equipment (WEEE). This means that this product must be handled pursuant to European Directive 2012/19/EU in order to be recycled or dismantled to minimize its impact on the environment. For further information, please contact your local or regional authorities. Electronic products not included in the selective sorting process are potentially dangerous for the environment and human health due to the presence of hazardous substances. We, eKids declare that this device complies with the essential requirements of the RED Directive 2014/53/EU. The following test methods have been applied in order to prove presumption of conformity with the essential requirements of the RED Directive 2014/53/EU



Getting Started

Installing the Batteries

Note: Batteries should always be installed by an adult.

- 1 Use a Phillips screwdriver to open the battery compartment door located on the back of the unit.
- 2 Insert 2 new AAA batteries into each Walkie Talkie with + and - terminals as indicated on the compartment door.
- 3 Replace the compartment door and tighten the screw with a Phillips screwdriver. Do not over-tighten the screw.

For the Best Possible Performance

- Only use the recommended/supplied batteries or equivalent.
- Use alkaline batteries for longer life.
- Do not mix old and new batteries, and do not mix alkaline, carbon-zinc or rechargeable nickel-cadmium batteries.
- Insert batteries with proper polarity (+/-) as indicated.
- Remove exhausted batteries from product.
- Recharge rechargeable batteries under adult supervision.
- Do not attempt to recharge non-rechargeable batteries.
- Do not open batteries or heat them beyond normal ambient temperatures.
- To prevent battery leakage or damage remove batteries from a product if it will not be used for a month or longer.
- Use extreme caution handling leaking batteries (avoid direct contact with eyes and skin). If battery leakage comes in contact with eyes, IMMEDIATELY flush the eye with lukewarm and gently flowing water for at least 30 minutes. If skin contact occurs, wash skin with clear water for at least 15 minutes. Seek medical attention if any symptoms occur.
- Store in cool, dry, ventilated area away from hazardous or combustible material.
- Do not dispose of batteries in the household trash or fire.
- Follow applicable laws and local regulations for the disposal and transportation of batteries.
- Rechargeable batteries are to be removed from the toy before being charged.
- The supply terminals are not to be short-circuited.

Playing Walkie Talkie Games

Walkie Talkies can be used for all kinds of fun games and activities. Here are two suggestions:

Hide and Seek

Just like regular Hide and Seek, but with a twist: the "Hider" can send clues to the "Seeker" using the Walkie Talkies.

Mystery Sounds

Can you recognize the mystery sound? One kid sends a sound over the Walkie Talkies, while another tries to guess what the sound is. Examples can include an animal, song, TV show, or anything else!

Installing the Batteries

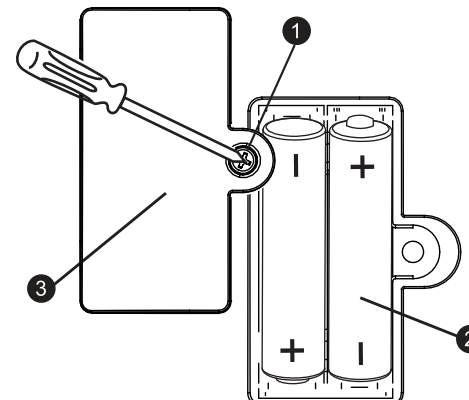
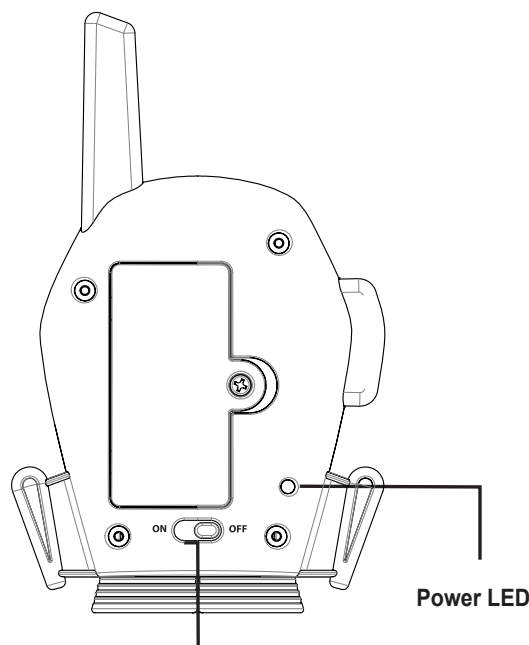

OFF/ON Button

Power LED

Antenna

Talk Button

Microphone/Speaker

Turning Power On/Off

- Slide the **ON/OFF Button** to the **ON** to activate the Walkie Talkies. The Power LED will glow solid.
- Slide the **ON/OFF Button** to the **OFF** to shut off the Walkie Talkies. The Power LED will turn off.
- **Both** Walkie Talkies must be turned on in order to send and receive messages.

Sending Voice Messages

Press and hold the **Talk Button** while speaking into the Microphone/Speaker.

You Should Know

For clear transmission, keep the Microphone approximately two inches from your mouth.

Receiving Messages

- Both Walkie Talkies must be turned on in order to send and receive messages.
- Messages cannot be received while your **Talk Button** is being pressed.
- Messages can be heard through the Microphone/Speaker.

Maintenance

It is important to keep the Walkie Talkies as dry and clean as possible. You may clean the cabinet with a cloth or sponge moistened with mild soap and water. Do not attempt to use strong cleansers or solvents, as they may cause damage.

Troubleshooting

If one or both of the Walkie Talkies do not work, this may indicate that the batteries are weak. Insert 2 new AAA batteries into each unit.

If the signal range of the Walkie Talkies decreases notably, this may again be an indication that the batteries are weak. Insert 2 new AAA batteries into each unit.

Please keep in mind that this product does not transmit well through obstacles such as trees, buildings, and metal structures.

If there is a sizable increase in static, it may be due to the proximity of electric motors, fluorescent lights, power lines, or other signal-disrupting objects. You may have to change your location.

If problems persist, DO NOT ATTEMPT TO REPAIR THE UNIT. See the Warranty for factory services.

Modèle: TS-202

TALKIES-WALKIES



Frequency: 434MHz This product bears the selective sorting symbol for waste electrical and electronic equipment (WEEE). This means that this product must be handled pursuant to European Directive 2012/19/EU in order to be recycled or dismantled to minimize its impact on the environment. For further information, please contact your local or regional authorities. Electronic products not included in the selective sorting process are potentially dangerous for the environment and human health due to the presence of hazardous substances. We, eKids declare that this device complies with the essential requirements of the RED Directive 2014/53/EU. This device complies with the essential requirements of the RED Directive 2014/53/EU. The following test methods have been applied in order to prove presumption of conformity with the essential requirements of the RED Directive 2014/53/EU

FR

UK
CA



CE

Mise en route

Installation des piles

Remarque : Les piles doivent toujours être installées par un adulte.

- 1 Utilisez un tournevis Phillips pour ouvrir le compartiment des piles situé à l'arrière de l'appareil.
- 2 Insérez 2 nouvelles piles AAA dans chaque Talkie Walkie avec les bornes + et - comme indiqué sur le compartiment à piles.
- 3 Remplacez le capot du compartiment et revissez la vis avec un tournevis Phillips. Ne serrez pas trop.

Pour obtenir une meilleure performance

- N'utilisez que des piles recommandées/fournies ou de type équivalent.
- Utilisez des piles alcalines pour une durée plus longue.
- Ne mélangez pas des piles neuves et usagées, des piles alcalines, carbone-zinc et nickel-cadmium rechargeables.
- Insérez les piles en respectant les polarités (+/-) indiquées.
- Enlevez les piles usées de l'appareil.
- Les piles rechargeables doivent être rechargées sous la supervision d'un adulte.
- Ne tentez pas de recharger des piles non rechargeables.
- N'ouvrez pas les piles ou ne les chauffez pas au-delà des températures ambiantes normales.
- Pour éviter toute fuite ou dommage de pile, enlevez les piles d'un produit si celui-ci ne va pas être utilisé pendant un mois ou plus.
- Utilisez une extrême prudence lors de la manipulation de piles qui fuient (évitent le contact direct avec les yeux et la peau). En cas de contact du liquide d'une pile avec les yeux, nettoyez immédiatement les yeux à grande eau tiède et les laisser en contact avec l'eau pendant au moins 30 minutes. En cas de contact avec la peau, lavez la peau avec de l'eau claire pendant au moins 15 minutes. Consultez un médecin si des symptômes apparaissent.
- A ranger dans un endroit frais, sec et aéré, loin des matières dangereuses et combustibles.
- Ne jetez pas les piles avec les ordures ménagères ou dans un feu.
- Suivez les lois applicables et les réglementations locales sur la mise au rebut et le transport de piles.
- Les piles rechargeables doivent être retirées du jouet avant d'être rechargées.
- Les bornes des piles ne doivent pas être court-circuitées.

Jouer à des jeux de talkie-walkies

Les talkie-walkies peuvent être utilisés pour toutes sortes de jeux et d'activités amusants. Voici deux suggestions :

Cache-cache

Tout comme un jeu de cache-cache normal mais avec un petit extra : celui qui se cache peut envoyer des indices au chercheur à l'aide de son talkie-walkies.

Les sons mystérieux

Pouvez-vous reconnaître le son mystère ? Un enfant envoie un son à l'aide de son talkie-walkies pendant que l'autre essaie de deviner de quel son il s'agit. Les sons peuvent être des sons d'animaux, des chansons, des séries télé ou tout autre chose !

Installation des piles

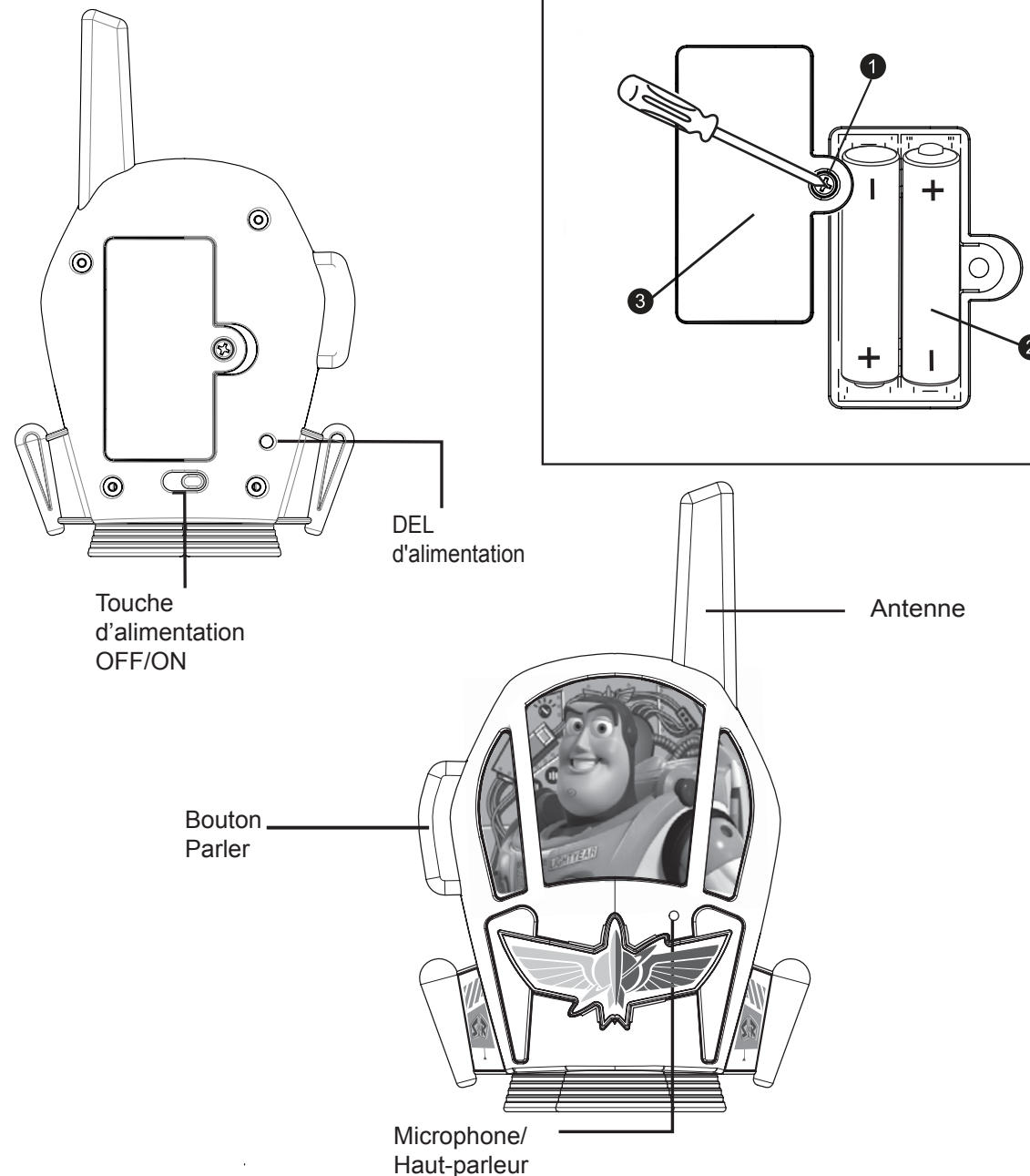

Marche/Arrêt

- Positionnez le commutateur ON/OFF sur ON pour allumer le Talkie-Walkie. Le témoin d'alimentation s'allume.
- Positionnez le commutateur ON/OFF sur OFF pour éteindre le Talkie-Walkie. Le témoin d'alimentation s'éteint.
- Les deux Talkie Walkies doivent être allumés pour pouvoir envoyer et recevoir des messages.

Envoi de messages vocaux

Maintenez appuyée la touche **Talk** tout en parlant dans le Microphone/Haut-parleur.

Ce que vous devez savoir

Pour une transmission claire, maintenez l'antenne vers le haut et le microphone à environ cinq centimètres de votre bouche.

Réception de messages

- Les deux talkie-walkies doivent être activés afin de pouvoir envoyer et recevoir des messages.
- Les messages ne peuvent pas être reçus tant que la touche Talk est appuyée.
- Les messages sont reproduits via le Microphone/Haut-parleur.

Maintenance

Il est important que les talkie-walkies restent secs et propres. Vous pouvez nettoyer l'enceinte avec un chiffon ou une éponge humidifiée avec un savon doux et de l'eau. N'essayez pas d'utiliser de nettoyants ou de solvants plus forts car ils peuvent endommager l'unité.

Dépannage

Si un ou les deux talkie-walkies ne fonctionnent pas, il se peut que les piles soient épuisées. Mettez 2 piles AAA neuves dans chaque appareil.

Si la portée du signal des talkie-walkies s'affaiblit fortement, ceci peut encore être une indication que les batteries sont épuisées. Mettez 2 piles AAA neuves dans chaque appareil. Veuillez vous souvenir que ce produit n'émet pas bien à travers les obstacles tels que les arbres, les bâtiments et les structures métalliques. Une importante augmentation des parasites peut être due à la proximité de moteurs électriques, de tubes fluorescents, de câbles électriques ou de tout autre objet dérangeant le signal. Il se peut que vous ayez à changer d'emplacement.

Si le problème persiste, N'ESSAYEZ PAS DE RÉPARER L'UNITÉ VOUS-MÊME. Regardez la garantie pour voir les conditions de réparation en usine

Modelo: TS-202

WALKIE TALKIES

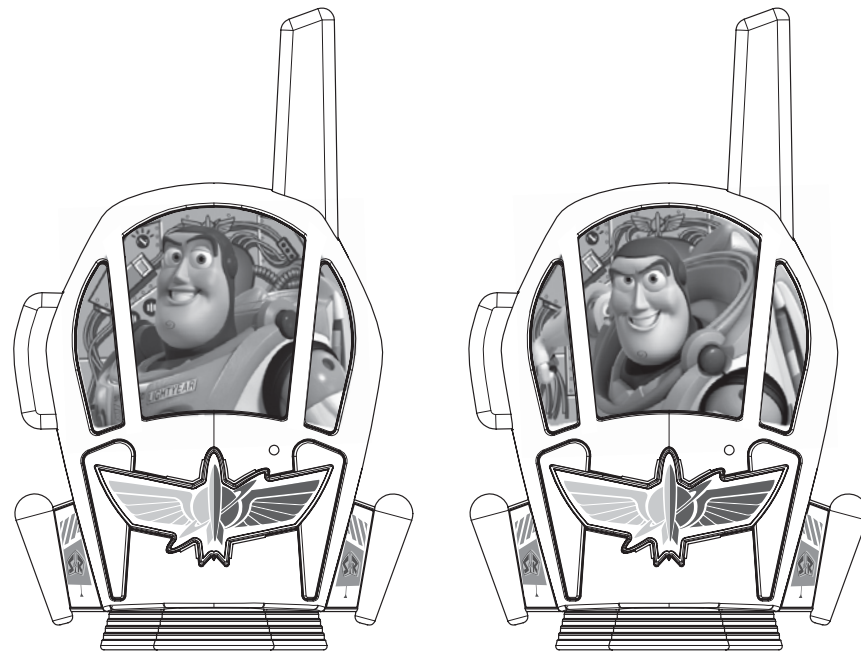

Frequency: 434MHz This product bears the selective sorting symbol for waste electrical and electronic equipment (WEEE). This means that this product must be handled pursuant to European Directive 2012/19/EU in order to be recycled or dismantled to minimize its impact on the environment. For further information, please contact your local or regional authorities. Electronic products not included in the selective sorting process are potentially dangerous for the environment and human health due to the presence of hazardous substances We, eKids declare that this device complies with the essential requirements of the RED Directive 2014/53/EU. This device complies with the essential requirements of the RED Directive 2014/53/EU. The following test methods have been applied in order to prove presumption of conformity with the essential requirements of the RED Directive 2014/53/EU

ES

UK
CA



CE

Primeros pasos

Instalación de las baterías

Nota: Las baterías debe instalarlas siempre un adulto.

- 1 Utilice un desarmador Phillips para abrir la tapa del compartimiento de baterías ubicado en la parte trasera de la unidad.
- 2 Inserte 2 baterías AAA nuevas en cada Walkie Talkie siguiendo las indicaciones en la tapa del compartimiento para la correcta colocación de las terminales + y -.
- 3 Vuelva a colocar la tapa del compartimiento y ajuste el tornillo con un desarmador Phillips. No ejerza sobrepresión al ajustar el tornillo.

Para el mejor desempeño posible

- Utilice sólo las baterías recomendadas/provistas o equivalentes.
- Utilice baterías alcalinas de duración prolongada.
- No combine baterías nuevas con usadas, ni alcalinas con carbón-zinc o recargables de níquel-cadmio.
- Inserte las baterías con la polaridad (+/-) correcta, como se indica.
- Extraiga de la unidad las baterías gastadas.
- Se requiere supervisión de adultos para recargar las baterías recargables.
- No intente recargar baterías no recargables.
- No abra las baterías ni las exponga a temperaturas superiores a las del ambiente.
- Para evitar fugas o daños en las baterías, extráigalas si la unidad no se usará durante un mes o más.
- Tenga extremo precaución con el manejo de baterías con fugas (evite el contacto directo con los ojos y la piel). Si se produce contacto con los ojos, INMEDIATAMENTE enjuague el ojo afectado con un flujo suave de agua tibia por lo menos durante 30 minutos. Si se produce contacto con la piel, lávela con agua limpia por lo menos durante 15 minutos. Busque atención médica si se presentan síntomas.
- Guardar en un sitio fresco, seco y ventilado, alejado de materiales peligrosos o combustibles.
- No arroje las baterías en la basura doméstica ni al fuego.
- Cumpla con las leyes y regulaciones locales para desechos y transporte de baterías.
- No deben retirarse del juguete las pilas recargables antes de cargarse.
- No deben cortocircuitarse las terminales de suministro.

Juegos con Walkie Talkies

Los Intercomunicadores Portátiles pueden usarse para toda clase de juegos y actividades divertidas. He aquí dos sugerencias:

Juego de las escondidas

Se puede jugar de la manera normal, pero con una modificación: El que está escondido envía pistas al que busca, usando los Intercomunicadores Portátiles.

Sonidos misteriosos

¿Puede reconocer el sonido misterioso? Un chico envía un sonido por el Intercomunicadores Portátiles, mientras que el otro intenta adivinar qué sonido es. Los ejemplos pueden incluir un animal, una canción, un programa de TV, ¡o cualquier otra cosa!

Instalación de las baterías

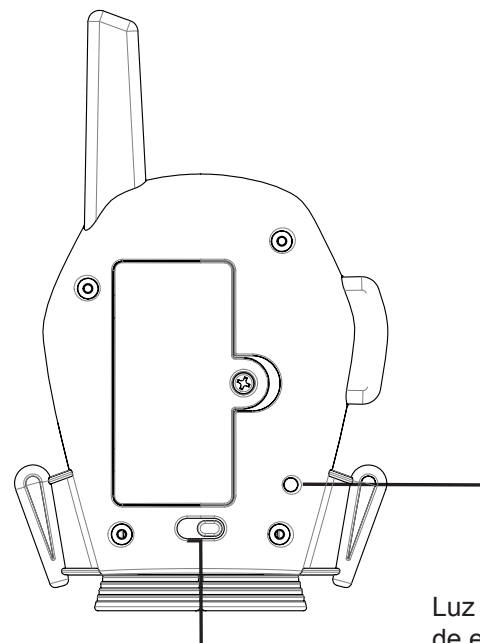
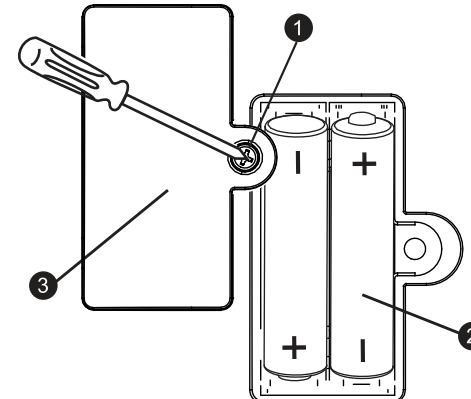

Botón de Apagado/ Encendido

Luz LED de encendido

Antena

Botón para Hablar

Micrófono /Altavoz

Encendido / Apagado

- Deslice el botón ON/OFF a la posición ON para activar los Walkie Talkies. El LED de encendido brillará de forma constante.
- Deslice el botón ON/OFF a la posición OFF para apagar los Walkie Talkies. El LED de encendido se apagará.
- Se deben encender ambos Walkie Talkies para enviar y recibir mensajes.

Envío de mensajes de voz

Presione y sostenga el botón **Talk** mientras hable al Micrófono/Altavoz de la unidad.

Lo que debe saber

Para una transmisión clara, mantenga la antena dirigida hacia arriba y el micrófono aproximadamente a dos pulgadas de su boca.

Recepción de mensajes

- Ambos Walkie Talkies deben estar encendidos para enviar y recibir mensajes.
- No se reciben mensajes mientras el **botón Talk** esté accionado.
- Los mensajes se escucharán por el Micrófono/Altavoz.

Mantenimiento

Es importante mantener los Intercomunicadores Portátiles tan secos y limpios como sea posible. Puede limpiar el exterior con un paño o esponja humedecidos con jabón neutro y agua. No intente utilizar limpiadores ni solventes fuertes, ya que ellos pueden causar daños.

Resolución de problemas

Si uno o ambos Walkie Talkies no funcionan, puede ser que las baterías estén gastadas. Inserte 2 baterías AAA nuevas en cada unidad.

Si el alcance de la señal de los Walkie Talkies se reduce notablemente, puede ser que las baterías están débiles. Inserte 2 baterías AAA nuevas en cada unidad. Por favor tenga en cuenta que este producto no transmite óptimamente a través de obstáculos como árboles, edificios y estructuras metálicas. Si la estática aumenta considerablemente, puede ser por la proximidad de motores eléctricos, luces fluorescentes, líneas eléctricas u otros objetos que interfieren la señal. Intente moverse a otra ubicación.

Si los problemas persisten, NO INTENTE REPARAR LA UNIDAD USTED MISMO. Consulte la garantía para ver la información relacionada con el servicio de la fábrica.

Modell: TS-202

WALKIE TALKIES



Frequency: 434MHz This product bears the selective sorting symbol for waste electrical and electronic equipment (WEEE). This means that this product must be handled pursuant to European Directive 2012/19/EU in order to be recycled or dismantled to minimize its impact on the environment. For further information, please contact your local or regional authorities. Electronic products not included in the selective sorting process are potentially dangerous for the environment and human health due to the presence of hazardous substances. We, eKids declare that this device complies with the essential requirements of the RED Directive 2014/53/EU. This device complies with the essential requirements of the RED Directive 2014/53/EU. The following test methods have been applied in order to prove presumption of conformity with the essential requirements of the RED Directive 2014/53/EU



Erste Schritte

Batterien einsetzen

Hinweis: Die Batterie sollte immer von einem Erwachsenen installiert werden.

- 1 Verwenden Sie einen Kreuzschlitzschraubenzieher und öffnen Sie damit die Batteriefachabdeckung an der Rückseite des Geräts.
- 2 Legen Sie in jedes Walkie Talkie 2 neue AAA-Batterien gemäß den Polaritätsmarkierungen (+ und -) auf der Abdeckung ein.
- 3 Ersetzen Sie den Batteriefachdeckel und ziehen Sie die Schraube mit einem Kreuzschlitz-Schraubendreher fest an. Ziehen Sie die Schraube nicht zu fest an.

Für die bestmögliche Leistung

- Verwenden Sie nur empfohlene/mitgelieferte oder gleichwertige Batterien.
- Verwenden Sie Alkali-Batterien für eine längere Lebensdauer.
- Mischen Sie nicht erschöpfte und frische Batterien oder Alkali- und Zink/Kohle-Batterien sowie Nickel-Cadmium-Akkus.
- Setzen Sie Batterien mit der korrekten Polarität (+/-) ein, wie angegeben.
- Entfernen Sie erschöpfte Batterien aus dem Gerät.
- Akkus müssen unter elterlicher Aufsicht geladen werden.
- Versuchen Sie nicht, gewöhnliche Batterien aufzuladen.
- Öffnen und erhitzen Sie Batterien nicht über die normalen Umgebungstemperaturen hinaus.
- Entfernen Sie die Batterien bei Nichtgebrauch für einen Monat oder länger aus dem Gerät, um ein Auslaufen zu vermeiden.
- Behandeln Sie ausgelaufene Batterien mit größter Vorsicht (vermeiden Sie direkten Augen- oder Hautkontakt). Gerät Ihnen Batteriesäure in die Augen, so spülen Sie die Augen UNVERZÜGLICH für wenigstens 30 Minuten mit lauwarmem Wasser aus. Bei Hautkontakt waschen Sie die betroffenen Stellen für wenigstens 15 Minuten mit klarem Wasser. Wenden Sie sich bei Problemen an einen Arzt.
- Kühl und trocken in gut belüftetem Bereich und fern von gefährlichen oder brennbaren Materialien lagern.
- Entsorgen Sie Batterien nicht mit dem Hausmüll und verbrennen Sie Batterien nicht.
- Entsorgen und transportieren Sie Batterien umweltgerecht.
- Batterien müssen separat und an einer lokalen Recyclingeinrichtung entsorgt werden. Werfen Sie Batterien nicht in den Hausmüll.
- Wiederaufladbare Akkus müssen aus dem Spielzeug entfernt werden, bevor sie aufgeladen werden.
- Die Stromversorgungsklemmen dürfen nicht kurzgeschlossen werden.

Walkie Talkie Spiele

Sie können Walkie Talkies für unterschiedliche Spiele verwenden. Hier zwei Beispiele:

Verstecken

Ähnlich wie das normale Versteckspielen, jedoch mit einem Twist: der Spieler, der sich versteckt, kann dem Spieler, der ihn sucht, mit dem Walkie Talkie „Hinweise“ geben.

Mysteriöse Geräusche

Können Sie den Sound erkennen? Ein Kind sendet ein Geräusch über das Walkie Talkie, und das Kind am anderen Ende versucht zu erraten, um was für ein Geräusch es sich handelt. Senden Sie Tiergeräusche, Lieder, TV-Sendungen, oder ähnliches!

Batterieinstallation

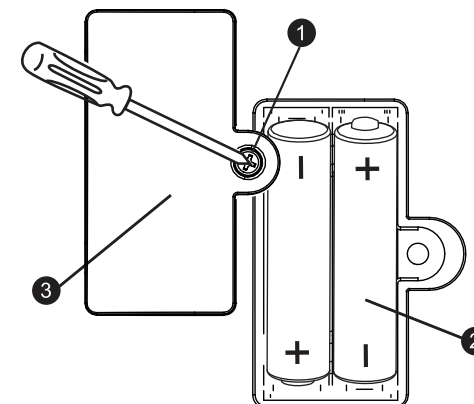
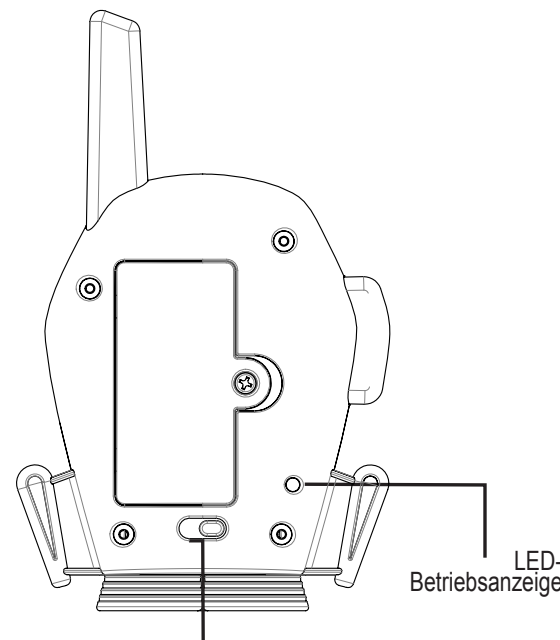

EIN/AUS-Taste

Antenne

Sprech-Taste

Mikrofon/
Lautsprecher

Ein-/Ausschalten

- Schieben Sie den ON/OFF-Schalter in die Position ON, um die Walkie Talkies einzuschalten. Die Power-LED leuchtet dauerhaft.
- Schieben Sie den ON/OFF-Schalter in die Position OFF, um die Walkie Talkies auszuschalten. Die Power-LED erlischt.
- Beide Walkie Talkies müssen eingeschaltet sein, um Sprachnachrichten zu senden und zu empfangen.

Sprachmitteilungen senden

Halten Sie die Sprech-Taste gedrückt, während Sie in das Mikrofon/ den Lautsprecher sprechen.

Beachten Sie

Halten Sie zwischen Mikrofon und Mund einen Abstand von ungefähr 5 cm ein, um eine klare Übertragung zu gewährleisten.

Nachrichten empfangen

- Beide Walkie Talkies müssen eingeschaltet sein, um Nachrichten senden und empfangen zu können.
- Während die Sprech-Taste gedrückt ist, können Sie keine Nachrichten empfangen.
- Die Nachricht wird über das Mikrofon/ den Lautsprecher wiedergegeben.

Pflege

Die Walkie Talkies müssen immer so trocken und sauber wie möglich sein. Reinigen Sie das Gehäuse mit einem feuchten Tuch oder Schwamm und ggf. etwas mildem Reinigungsmittel. Verwenden Sie keine aggressiven Reinigungs- oder Lösungsmittel, das führt zu Schäden am Gerät.

Problembehandlung

Falls ein oder beide Walkie Talkies nicht funktionieren, ist dies möglicherweise ein Anzeichen für schwache Batterien. Legen Sie in jedes Gerät 2 neue AAA-Batterien ein.

Falls die Reichweite der Walkie Talkies deutlich nachlässt, ist dies ein weiteres Anzeichen für schwache Batterien. Legen Sie in jedes Gerät 2 neue AAA-Batterien ein. Bitte beachten Sie, dass die Übertragung dieses Produkts durch Hindernisse wie Bäume, Gebäude und Metallgegenstände beeinträchtigt wird.

Falls deutlich mehr Störgeräusche auftreten als normal, sind in der Nähe des Produkts möglicherweise elektrische Motoren, fluoreszierende Lampen, Stromleitungen oder andere signalstörende Gegenstände vorhanden. Ändern Sie ggf. Ihren Standort.

Falls das Problem weiterhin besteht, VERSUCHEN SIE NICHT, DAS GERÄT ZU REPARIEREN. Siehe Garantie für Kundendienstleistungen

Modelo: TS-202

WALKIE TALKIES

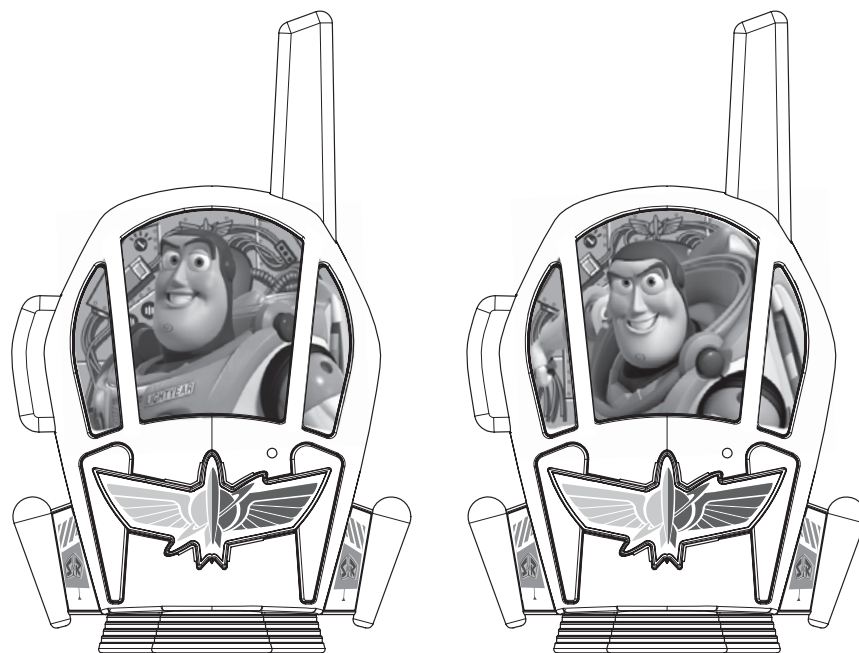

Frequency: 434MHz This product bears the selective sorting symbol for waste electrical and electronic equipment (WEEE). This means that this product must be handled pursuant to European Directive 2012/19/EU in order to be recycled or dismantled to minimize its impact on the environment. For further information, please contact your local or regional authorities. Electronic products not included in the selective sorting process are potentially dangerous for the environment and human health due to the presence of hazardous substances. We, eKids declare that this device complies with the essential requirements of the RED Directive 2014/53/EU. This device complies with the essential requirements of the RED Directive 2014/53/EU. The following test methods have been applied in order to prove presumption of conformity with the essential requirements of the RED Directive 2014/53/EU

PT

UK
CA



CE

Início

Instalação da Pilha

- Nota: As pilhas devem ser sempre instaladas por um adulto.
- 1 Usar uma chave Phillips, abrir a tampa do compartimento das pilhas localizada na parte de trás da unidade.
 - 2 Introduzir as 2 pilhas novas AAA no compartimento das mesmas. Certificar que as pilhas coincidem com o + e - indicado no diagrama do compartimento da pilha.
 - 3 Voltar a colocar a porta do compartimento da pilha. Não apertar demasiado o parafuso.

- Cuidados na utilização das pilhas e Dicas de segurança e Melhor desempenho**
- Usar apenas as pilhas recomendadas/fornecidas ou equivalentes.
- Usar pilhas alcalinas para obter uma maior duração.
 - Não misturar pilhas usadas com pilhas novas, e não misturar pilhas alcalinas com pilhas de zinco-carbono ou pilhas recarregáveis de níquel-cádmio.
 - Introduzir as pilhas com a polaridade correta (+/-) conforme indicado.
 - Retirar do aparelho as pilhas já gastas.
 - Recarregar as pilhas recarregáveis sob a supervisão de um adulto.
 - Não tentar recarregar pilhas não recarregáveis.
 - Não abrir as pilhas nem as aquecer para além da temperatura ambiente normal.
 - Para impedir que ocorra um derramamento ou fuga, remover as pilhas do aparelho se este não for para ser utilizado durante um mês ou mais.
 - Ter o máximo cuidado no manuseamento de pilhas com derramamentos (evitar o contacto direto com os olhos e a pele). Se ocorrer um contacto com os olhos, deve lavar IMEDIATAMENTE o olho com água morna e enxaguar suavemente durante pelo menos 30 minutos. Se ocorrer um contato com a pele, lavar a pele com água limpa durante pelo menos 15 minutos. Procurar aconselhamento médico se ocorrerem alguns sintomas.
 - Armazenar numa zona fresca, seca, ventilada afastada de material combustível e perigoso.
 - Não eliminar as pilhas com o lixo doméstico ou no fogo.
 - Seguir a legislação e as regulamentações locais aplicáveis para a eliminação e transporte de pilhas.
 - As baterias recarregáveis devem ser retiradas do brinquedo antes de serem recarregadas.
 - Os terminais de alimentação não devem ser curto-circuitados.

Jogar jogos com os Walkie-Talkies

Os Walkie-Talkies podem ser usados em todos os tipos de jogos e atividades de lazer. Damos aqui duas sugestões:

Jogar às escondidas

Tal como num jogo normal às escondidas, mas com uma variante: o "Que se esconde" envia pistas ao "Que procura" com os Walkie-Talkies.

Sons misteriosos

Consegue reconhecer um som misterioso? Uma criança envia um som através dos Walkie-Talkies, enquanto a outra tenta adivinhar qual é esse som. Os exemplos podem incluir um animal, uma canção, um espetáculo de televisão ou qualquer outro!

Instalação da Pilha

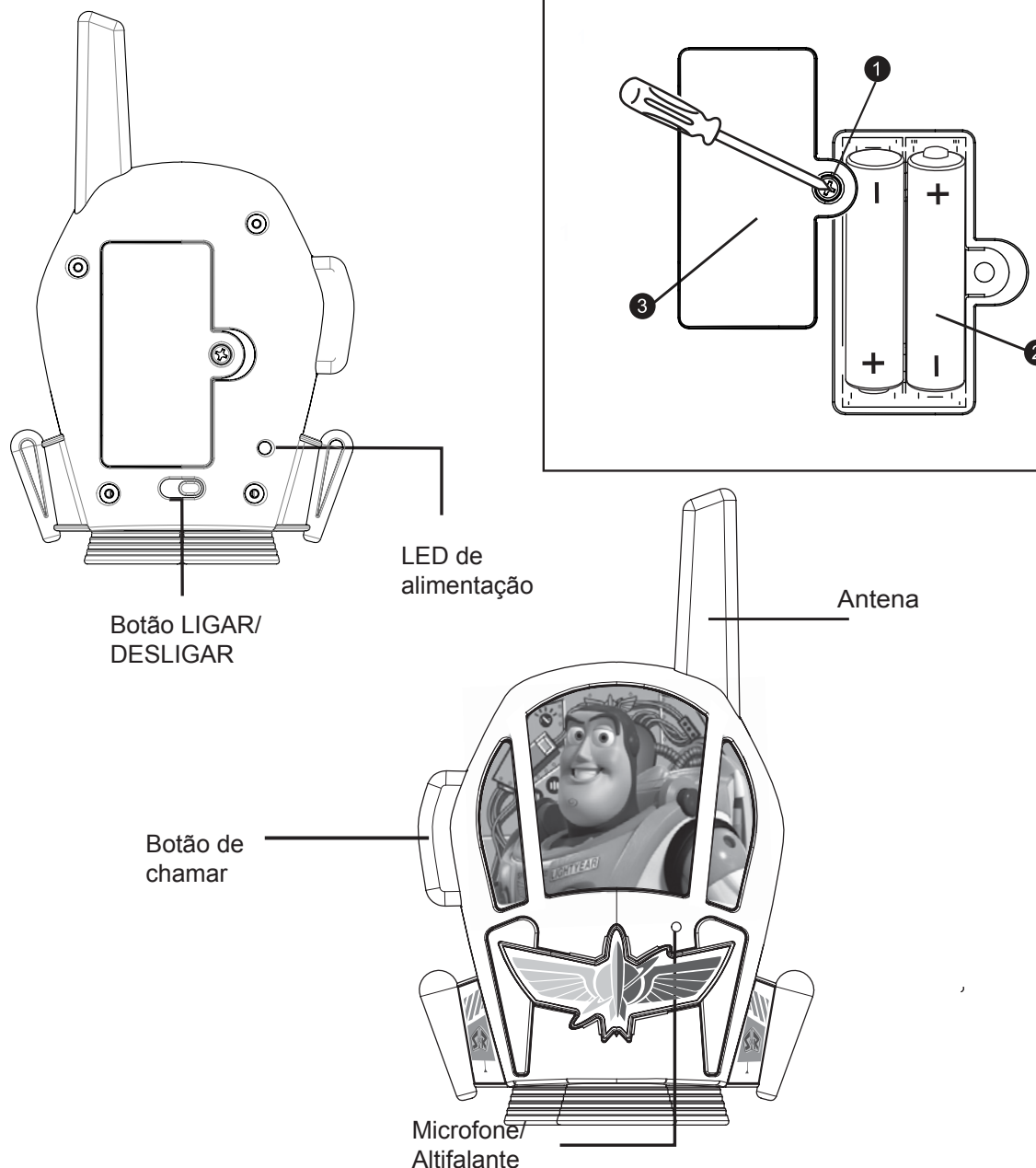

Ligar/Desligar

- Deslizar o botão ON/OFF para ON para ativar os Walkie-Talkies. O LED de alimentação fica com um brilho contínuo.
- Deslizar o botão ON/OFF para OFF para desligar os Walkie-Talkies. O LED de alimentação desligar-se-á.
- Ambos os Walkie-Talkies devem estar ligados de modo a enviarem e receberem mensagens.

Enviar Mensagens de Voz

Press and hold the Talk button while speaking into the Microphone/Speaker. Premir e manter premido o botão Falar enquanto está a falar no Microfone/Altifalante.

A saber

Para uma transmissão nítida, deve manter o Microfone a aproximadamente 50 cm da sua boca.

Receber mensagens

- Ambos os Walkie-Talkies devem estar ligados de modo a enviarem e receberem mensagens.
- As mensagens não podem ser recebidas enquanto o botão **Falar** estiver a ser premido.
- As mensagens podem ser ouvidas através do Microfone/Altifalante.

Manutenção

É importante manter os Walkie-Talkies o mais secos e o mais limpos possível. Pode limpar a caixa de proteção exterior com um pano ou uma esponja humedecidos com um detergente suave e água. Não tentar usar soluções de limpeza fortes pois podem dar origem a danos.

Resolução de problemas

Se um ou ambos os Walkie-Talkies não funcionarem, isso pode ser indicativo que as pilhas estão fracas. Introduzir 2 pilhas AAA em cada um dos aparelhos.

Se o alcance do sinal dos Walkie-Talkies diminuir significativamente, isso pode igualmente ser uma indicação que as pilhas estão fracas. Introduzir 2 pilhas AAA em cada um dos aparelhos.

Deve ter em atenção que este produto não transmite bem através de obstáculos, como árvores, edifícios e estruturas de metal. Se houver um aumento considerável da carga estática, isso pode ser devido à proximidade de motores elétricos, luzes fluorescentes, linhas de alimentação ou outros objetos que interferem com o sinal. Pode ser necessário mudar a sua localização.

Modello: TS-202

WALKIE TALKIE

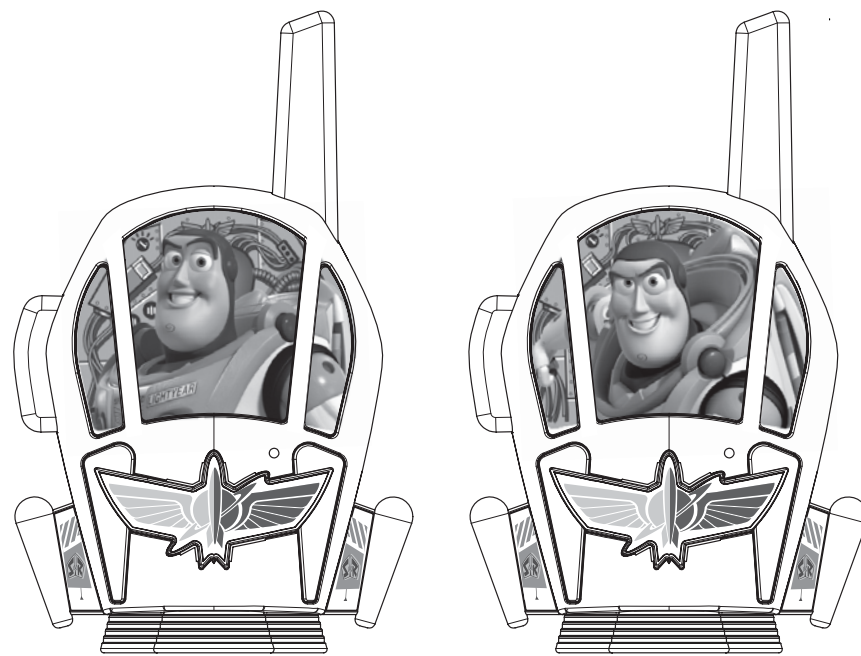

Frequency: 434MHz This product bears the selective sorting symbol for waste electrical and electronic equipment (WEEE). This means that this product must be handled pursuant to European Directive 2012/19/EU in order to be recycled or dismantled to minimize its impact on the environment. For further information, please contact your local or regional authorities. Electronic products not included in the selective sorting process are potentially dangerous for the environment and human health due to the presence of hazardous substances We, eKids declare that this device complies with the essential requirements of the RED Directive 2014/53/EU. This device complies with the essential requirements of the RED Directive 2014/53/EU. The following test methods have been applied in order to prove presumption of conformity with the essential requirements of the RED Directive 2014/53/EU

IT



Cenni introduttivi

Inserimento delle batterie

Nota: La batteria deve essere sempre installata da un adulto.

- 1 Utilizzare un cacciavite Phillips piccolo per aprire il vano batterie che si trova sul retro dell'unità.
- 2 Inserire 2 batterie AAA nuove nel vano batterie. Assicurarsi che le batterie corrispondano al + e - come indicato nel diagramma nel vano batteria.
- 3 Riposizionare il coperchio del vano batteria. Non serrare eccessivamente la vite.

Per le migliori prestazioni possibili

- Utilizzare solo le batterie raccomandate/fornite o equivalenti.
- Utilizzare batterie alcaline per maggiore durata.
- Non mischiare batterie vecchie e nuove e non mischiare batterie alcaline, zinco-carbonio o nickel-cadmio ricaricabili.
- Inserire le batterie con la corretta polarità (+/-) come indicato.
- Rimuovere le batterie esaurite dal prodotto.
- Ricaricare batterie ricaricabili sotto la supervisione di adulti.
- Non cercare di ricaricare batterie non ricaricabili.
- Non aprire le batterie o riscaldarle oltre la temperatura ambiente normale.
- Per prevenire perdite o danneggiamento della batteria, rimuovere le batterie da un prodotto se non sarà usato per un periodo prolungato di tempo.
- Utilizzare estrema cautela nel gestire le batterie che perdono (evitare il contatto diretto con occhi e pelle). Se la perdita della batteria entra a contatto con gli occhi, sciacquare IMMEDIATAMENTE gli occhi con acqua corrente tiepida per almeno 30 minuti. In caso di contatto con la pelle, lavare con acqua pulita per almeno 15 minuti. Se i sintomi persistono consultare il medico.
- Conservare in un'area fresca, asciutta e ventilata lontano da materiale pericoloso o combustibile.
- Non smaltire le batterie nei rifiuti domestici o fuoco.
- Osservare le leggi e disposizioni locali applicabili per lo smaltimento e il trasporto delle batterie.
- Le batterie devono essere smaltite separatamente presso un centro di riciclaggio di rifiuti locale. Non smaltire nei rifiuti domestici.
- Le batterie ricaricabili devono essere rimosse dal giocattolo prima di essere caricate.
- I terminali di alimentazione non devono essere cortocircuitati.

Giocare ai giochi del Walkie Talkie

I Walkie Talkie possono essere usati per tutti i tipi di giochi e attività divertenti. Ecco due suggerimenti:

Nascondino

Proprio come il normale Nascondino, ma con una modifica: "Chi si nasconde" può inviare indizi a "Chi cerca" usando i Walkie Talkie.

Suoni misteriosi

Puoi riconoscere il suono misterioso? Un bambino invia un suono con il Walkie Talkie, mentre un altro cerca di capire di che suono si tratta. Gli esempi possono includere un animale, una canzone, uno spettacolo televisivo o qualsiasi altra cosa!

Inserimento delle batterie

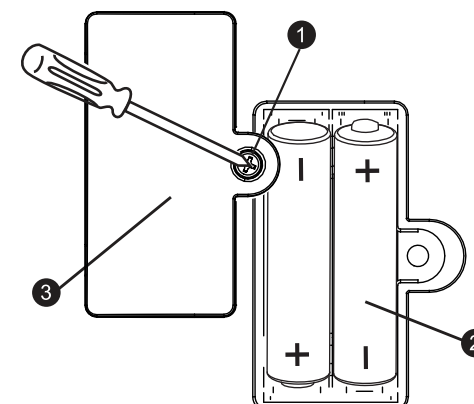
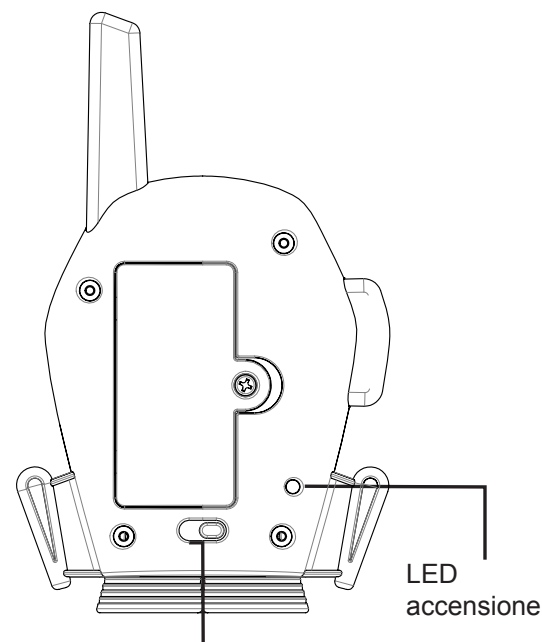

Pulsante ON/OFF

Antenna

Pulsante rispondi

Microfono/Altoparlante

Accensione/Spegnimento

- Portare il pulsante ON/OFF su ON per attivare i walkie talkie. Il LED di alimentazione si accende fisso.
- Portare il pulsante ON/OFF su OFF per spegnere i walkie talkie. Il LED di alimentazione si spegne.
- Entrambi i walkie talkie devono essere accesi per inviare e ricevere messaggi.

Invio di messaggi vocali

Premere e tenere premuto il pulsante Talk mentre si parla al Microfono/Altoparlante.

Ciò che devi sapere

Per una trasmissione chiara, tenere il microfono a circa due pollici dalla bocca.

Ricezione di messaggi

- Entrambi i Walkie Talkie devono essere accesi per inviare e ricevere messaggi.
- I messaggi possono essere ricevuti mentre si preme il pulsante Talk.
- I messaggi possono essere sentiti attraverso il microfono/altoparlante.

Manutenzione

È importante tenere i Walkie Talkie quanti più asciutti e puliti possibili. Pulire la superficie con una spugna o un panno inumidito con sapone delicato e acqua. Non utilizzare detergenti aggressivi, in quanto potrebbero causare danni.

Risoluzione dei problemi

Se uno o entrambi i Walkie Talkie non funzionano, ciò può indicare che le batterie sono scariche. Inserire 2 batterie AAA nuove in ogni unità.

Se la portata del segnale dei Walkie Talkie diminuisce in modo considerevole, ciò può essere nuovamente un'indicazione che le batterie sono scariche. Inserire 2 batterie AAA nuove in ogni unità.

Ricordarsi che questo prodotto non trasmette bene attraverso ostacoli come alberi, edifici e strutture metalliche. Se vi è un notevole aumento statico, può essere dovuto alla prossimità di motori elettrici, luci fluorescenti, linee elettriche o altri oggetti che disturbano il segnale. Potrebbe essere necessario cambiare la posizione.

Se i problemi persistono, NON TENTARE DI RIPARARE L'UNITÀ. Si veda la Garanzia per i servizi di fabbrica.

Modele: TS-202

WALKIE-TALKIES

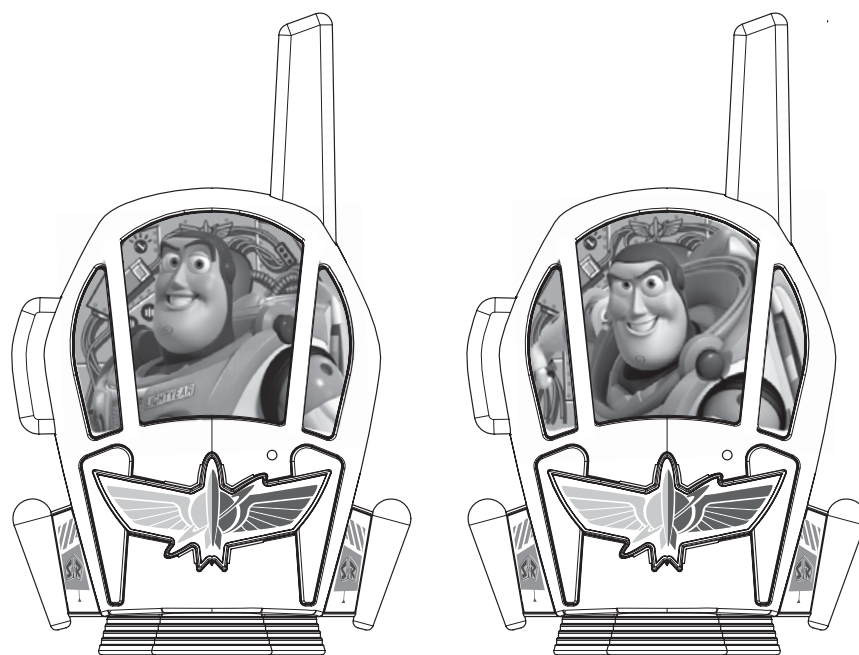

Frequency: 434MHz This product bears the selective sorting symbol for waste electrical and electronic equipment (WEEE). This means that this product must be handled pursuant to European Directive 2012/19/EU in order to be recycled or dismantled to minimize its impact on the environment. For further information, please contact your local or regional authorities. Electronic products not included in the selective sorting process are potentially dangerous for the environment and human health due to the presence of hazardous substances We, eKids declare that this device complies with the essential requirements of the RED Directive 2014/53/EU. This device complies with the essential requirements of the RED Directive 2014/53/EU. The following test methods have been applied in order to prove presumption of conformity with the essential requirements of the RED Directive 2014/53/EU

PL

UK
CA



CE

Início

Wkładanie baterii

Nota: As pilhas devem ser sempre instaladas por um adulto.

- 1 Wkrętakiem krzyżowym należy otworzyć drzwiczki komory baterii znajdujące się z tyłu urządzenia.
- 2 Włożyć 2 nowe baterie AAA do komory baterii. Upewnić się, że baterie są włożone zgodnie z oznaczeniami + i -, tak jak wskazano na schemacie w komorze baterii.
- 3 Założyć drzwiczki komory baterii. Nie dokręcać za mocno śruby.

Ważne informacje dotyczące baterii:

- Po wyczerpaniu baterii, należy używać tylko zalecanych lub podobnych baterii
- Należy używać baterii alkalicznych o dłuższym okresie żywotności
- Nie należy mieszać starych i nowych baterii ani ich różnych typów i marek (alkalicznych, cynkowo-węglowych z niklowo-kadmowych)
- Zachowaj ostrożność przy wkładaniu/wymienianiu baterii, zachowując odpowiednią polaryzację (+/-)
- Wyrzucić zużyte baterie
- Baterie z możliwością ponownego ładowania, powinny być ładowane pod nadzorem dorosłych
- Nie próbuj ładować baterii jednorazowych
- Nie próbuj otwierać baterii i przechowuj je we właściwy sposób: w chłodnym, suchym miejscu w temperaturze pokojowej, z dala od materiałów niebezpiecznych i łatwopalnych
- Pozbądź się nieużywanych przez dłuższy czas baterii (miesiąc lub dłużej), aby uniknąć wycieku elektrolitu i uszkodzenia produktu
- Należy zachować szczególną ostrożność przy wycieku baterii, lub przy nieszczelnym bateriach (unikaj bezpośredniego kontaktu ze skórą lub oczami). Jeśli oczy miały kontakt z płynem baterii, należy je NATYCHMIAST przepłukać letnią, czystą wodą przez co najmniej 30 minut. Jeśli twoja skóra miała kontakt z płynem baterii, należy ją przemyć przez co najmniej 15 minut czystą wodą. Jeśli pojawią się dziwne objawy, proszę zasięgnąć porady lekarza tak szybko, jak to tylko możliwe.
- Baterie nie należy wyrzucać do śmieci, ani nie należy pozbywać się ich poprzez spalanie
- Postępuj zgodnie z obowiązującymi zasadami i przepisami w zakresie usuwania i transportu baterii w miejscu zamieszkania
- Baterie należy utylizować w odpowiednich miejscach recyklingu.
- Przed ładowaniem należy wyjąć akumulatory z zabawki.
- Nie wolno doprowadzić do zwarcia styków zasilania.

Jogar jogos com os Walkie-Talkies

Os Walkie-Talkies podem ser usados em todos os tipos de jogos e atividades de lazer. Damos aqui duas sugestões:

Jogar às escondidas

Tal como num jogo normal às escondidas, mas com uma variante: o "Que se esconde" envia pistas ao "Que procura" com os Walkie-Talkies.

Sons misteriosos

Consegue reconhecer um som misterioso? Uma criança envia um som através dos Walkie-Talkies, enquanto a outra tenta adivinhar qual é esse som. Os exemplos podem incluir um animal, uma canção, um espetáculo de televisão ou qualquer outro!

Wkładanie baterii

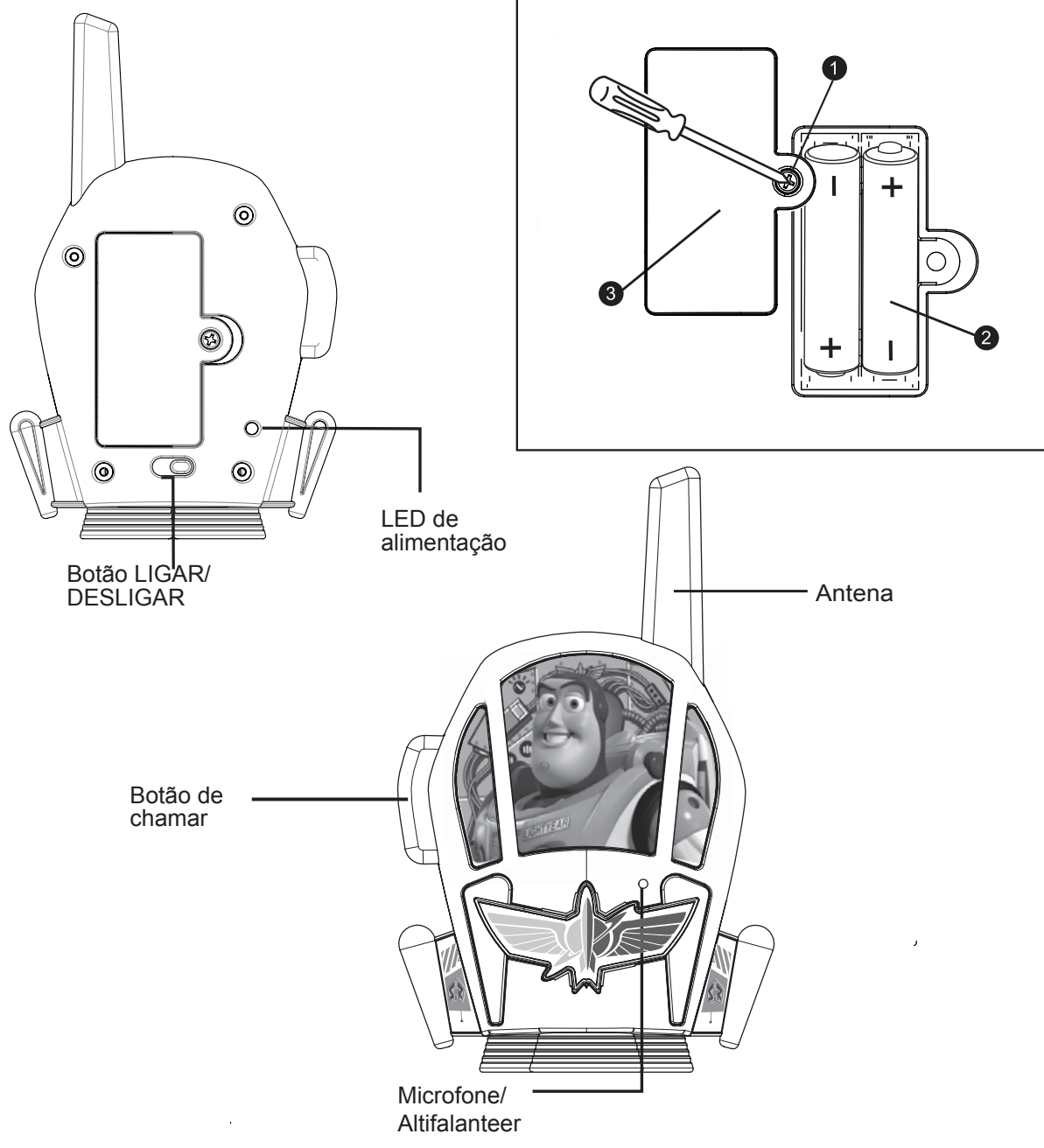

Ligar/Desligar

- Przesuń suwak ON/OFF do pozycji ON, by włączyć krótkofalówkę. Zapali się wskaźnik zasilania LED.
- Przesuń suwak ON/OFF do pozycji OFF, by wyłączyć krótkofalówkę. Wskaźnik zasilania LED zgaśnie.
- Aby wysłać i odbierać wiadomości, obie krótkofalówki muszą być włączone.

Enviar Mensagens de Voz

Premir e manter premido o botão Falar enquanto está a falar no Microfone/Altifalante.

A saber

Para uma transmissão nítida, deve manter o Microfone a aproximadamente 5 cm da sua boca.

Receber mensagens

- Ambos os Walkie-Talkies devem estar ligados de modo a enviarem e receberem mensagens.
- As mensagens não podem ser recebidas enquanto o botão Falar estiver a ser premido.
- As mensagens podem ser ouvidas através do Microfone/Altifalante.

Manutenção

É importante manter os Walkie-Talkies o mais secos e o mais limpos possível. Pode limpar a caixa de proteção exterior com um pano ou uma esponja humedecidos com um detergente suave e água. Não tentar usar soluções de limpeza fortes pois podem dar origem a danos.

Resolução de problemas

Se um ou ambos os Walkie-Talkies não funcionarem, isso pode ser indicativo que as pilhas estão fracas. Introduzir 2 pilhas AAA em cada um dos aparelhos.

Se o alcance do sinal dos Walkie-Talkies diminuir significativamente, isso pode igualmente ser uma indicação que as pilhas estão fracas. Introduzir 2 pilhas AAA em cada um dos aparelhos.

Deve ter em atenção que este produto não transmite bem através de obstáculos, como árvores, edifícios e estruturas de metal. Se houver um aumento considerável da carga estática, isso pode ser devido à proximidade de motores elétricos, luzes fluorescentes, linhas de alimentação ou outros objetos que interferem com o sinal. Pode ser necessário mudar a sua localização.

Se o problema persistir, NÃO TENTAR REPARAR O APARELHO. Consultar a Garantia para a assistência de fábrica.

Model: TS-202

WALKIE-TALKIER

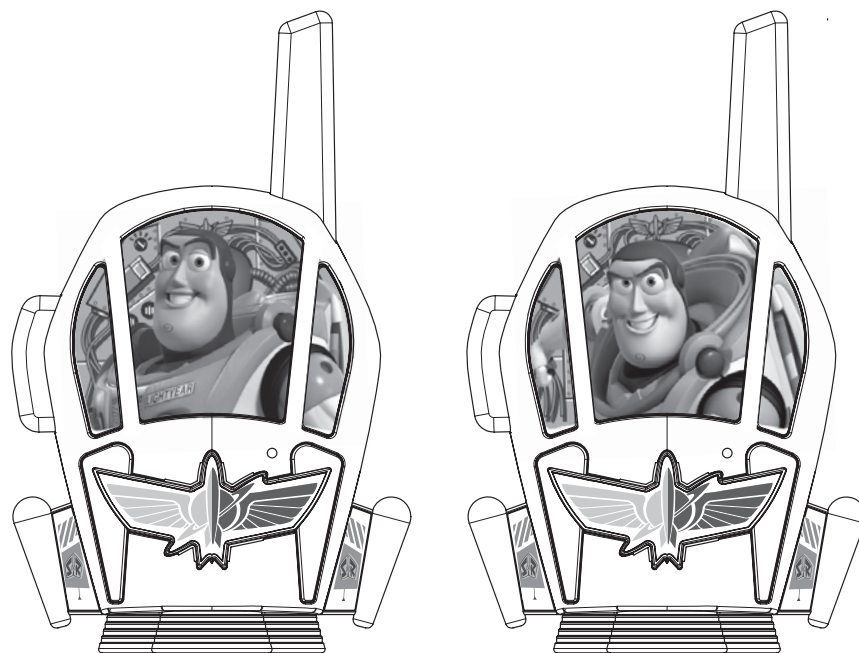

Frequency: 434MHz This product bears the selective sorting symbol for waste electrical and electronic equipment (WEEE). This means that this product must be handled pursuant to European Directive 2012/19/EU in order to be recycled or dismantled to minimize its impact on the environment. For further information, please contact your local or regional authorities. Electronic products not included in the selective sorting process are potentially dangerous for the environment and human health due to the presence of hazardous substances. We, eKids declare that this device complies with the essential requirements of the RED Directive 2014/53/EU. This device complies with the essential requirements of the RED Directive 2014/53/EU. The following test methods have been applied in order to prove presumption of conformity with the essential requirements of the RED Directive 2014/53/EU

NL

UK
CA



CE

Komme i gang

De batterijen plaatsen

Merk: Batteriene skal kun betjenes av voksne.

- 1 Gebruik een Phillips schroevendraaier, open het batterijvak aan de achterkant van het apparaat.
- 2 Plaats 2 nieuwe AAA -batterijen in het batterijvak. Zorg ervoor dat de batterijen overeenkomen met de + en - zoals aangeduid in het diagram van het batterijvak.
- 3 Plaats de klep van het batterijvak terug. Schroef de schroeven niet te vast.

Voor de beste prestatie

- Gebruik alleen de aanbevolen/geleverde batterijen of een equivalent hiervan.
- Gebruik alkalinebatterijen voor een langere levensduur.
- Combineer geen oude en nieuwe batterijen en combineer geen alkaline-, koolstof-zink- of oplaadbare nikkel-cadmiumbatterijen.
- Plaats de batterijen met de juiste polariteit (+/-) zoals aangegeven.
- Verwijder lege batterijen uit het product.
- Laad oplaadbare batterijen op onder toezicht van volwassenen.
- Probeer niet-oplaadbare batterijen niet op te laden.
- Open batterijen niet of verwarm batterijen niet boven kamertemperatuur.
- Verwijder batterijen uit het product als u ze voor een maand of langer niet gaat gebruiken, om batterijlekkage of beschadiging te voorkomen.
- Wees uiterst voorzichtig wanneer u te maken heeft met lekkende batterijen (vermijd direct contact met ogen en huid). Als batterijlekkage in contact komt met uw ogen, dient u ONMIDDELIJK uw ogen uit te spoelen met lauwwarm, zachtstromend water voor minstens een half uur. Als u te maken heeft met huidcontact, dient u de huid met helder water te wassen voor minstens een kwartier. Zoek medische hulp indien zich symptomen voordoen.
- Bewaar op een koele, droge, geventileerde plek uit de buurt van gevaarlijk of ontvlambaar materiaal.
- Gooi de batterijen niet weg met het huisvuil of in vuur.
- Volg toepasselijke wetten en plaatselijke voorschriften voor het weggooien en transporteren van batterijen.
- Batterijen afzonderlijk worden verwijderd bij uw lokale afvalverwerkingscentrum. Verwijder ze niet in het huishoudelijk afval.
- Oplaadbare batterijen moeten uit het speelgoed worden verwijderd voordat ze worden opgeladen.
- De stroomaansluitingen mogen geen kortsluiting krijgen.

Leke walkie talkie-leker

Walkie-talkier kan brukes til mange typer leker og morsomme aktiviteter. Her er to forslag:

Gjemsel

Akkurat som vanlig gjemsel, med en liten forbedring: Den som gjemmer seg kan bruke walkie-talkien til å sende hint til den som leter.

Mystiske lyder

Kjenner du igjen den mystiske lyden? En person sender lyder med walkie-talkien, mens den andre prøver å gjette hvilke lyder det er. Det kan for eksempel være dyrelyder, sanger, lyder fra TV-serier eller hva som helst annet.

De batterijen plaatsen

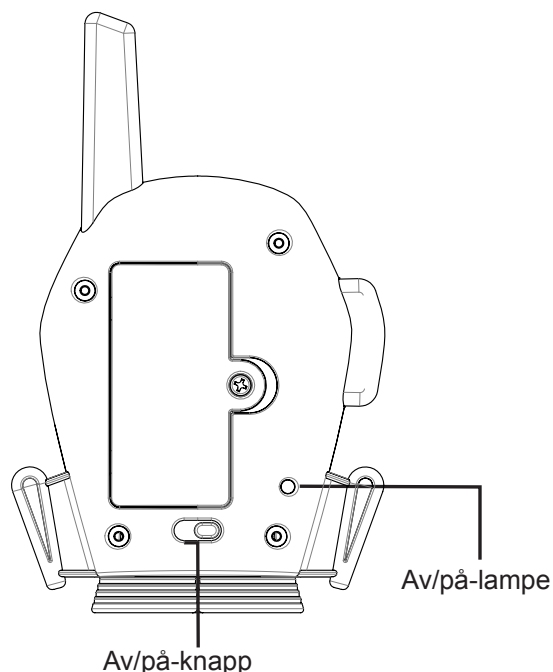
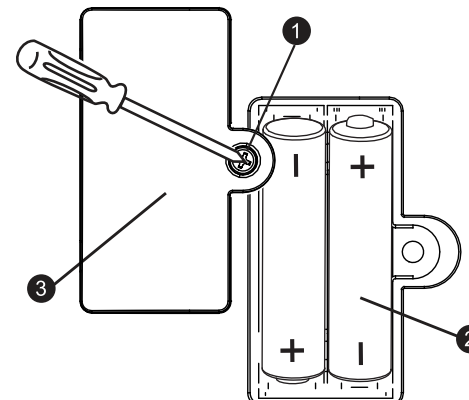

Av/på-knapp

Av/på-lampe

Antenne

Sendeknapp



Mikrofon/
høytaler

Skru av/på

- Schuif de ON/OFF -knop naar ON om de walkie-talkies te activeren. De aan/uit-LED begint de branden.
- Schuif de ON/OFF -knop naar OFF om de walkie-talkies uit te schakelen. De aan/uit-LED gaat uit.
- Beide walkie-talkies moeten ingeschakeld zijn om berichten te verzenden en te ontvangen.

Sende talemeldinger

Hold inne sendeknappen og snakk inn i mikrofonen/høytaleren.

Husk:

Hold mikrofonen omtrent 5 cm fra munnen, så blir lyden mest tydelig.

Motta meldinger

- Begge walkie-talkiene må skrus på for å sende og motta meldinger.
- Det går ikke an å motta meldinger mens sendeknappen er trykket inn.
- Meldingene høres fra mikrofonen/høytaleren.

Vedlikehold

Det er viktig å holde walkie-talkiene så rene og tørre som mulig. Du kan rengjøre kabinettet med en klut eller svamp som er fuktet med mild såpe og vann. Bruk aldri sterke rengjøringsmidler eller løsemidler, da disse kan skade enheten.

Feilsøking

Hvis en av eller begge walkie-talkiene ikke fungerer, kan det bety at det er lite batteri. Sett inn fire nye AAA-batterier i hver av enhetene.

Hvis sendeavstanden til walkie-talkien synker betydelig, kan det bety at det er lite batteri. Sett inn fire nye AAA-batterier i hver av enhetene.

Husk at dette produktet ikke kan sende gode signaler gjennom hindringer som trær, bygninger og metallstrukturer. Hvis du opplever en merkbar økning i mengden statisk støy, kan det skyldes at du er for nærme en elektrisk motor, et lysstoffrør, strømlinjer eller andre signalforstyrrende elementer. Det kan hende du må flytte deg til et annet sted.

Hvis problemene vedvarer, må du IKKE prøve å reparere enheten selv. Les garantien for informasjon om fabrikkjenester.

Modell: TS-202

WALKIE TALKIES

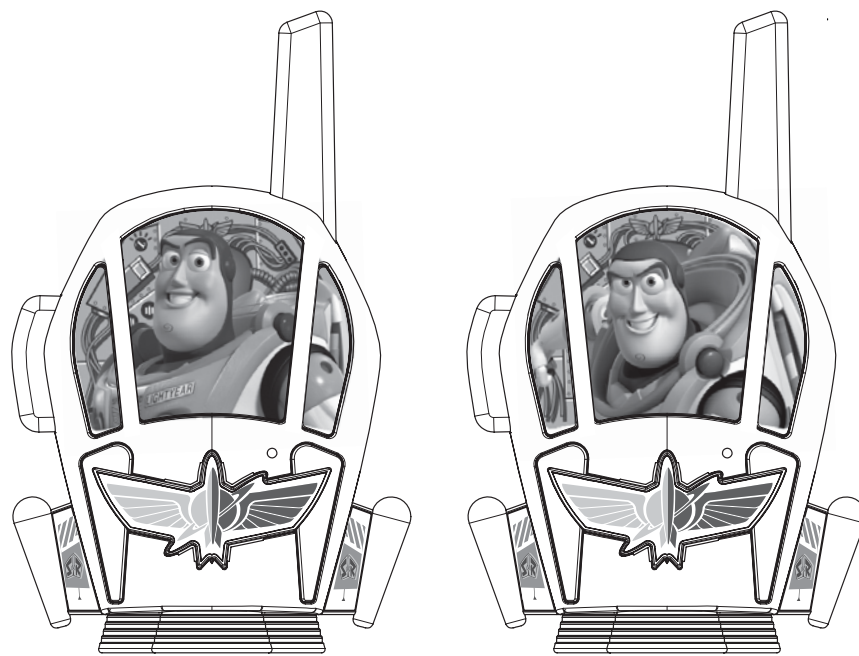

Frequency: 434MHz This product bears the selective sorting symbol for waste electrical and electronic equipment (WEEE). This means that this product must be handled pursuant to European Directive 2012/19/EU in order to be recycled or dismantled to minimize its impact on the environment. For further information, please contact your local or regional authorities. Electronic products not included in the selective sorting process are potentially dangerous for the environment and human health due to the presence of hazardous substances We, eKids declare that this device complies with the essential requirements of the RED Directive 2014/53/EU. This device complies with the essential requirements of the RED Directive 2014/53/EU. The following test methods have been applied in order to prove presumption of conformity with the essential requirements of the RED Directive 2014/53/EU

SE

UK
CA



CE

Komma igång

Installera batterier

OBS! Endast vuxna bör installera batterier.

- 1 Använd en stjärnskruvmejsel för att öppna batterifacket som sitter på enhetens baksida.
- 2 Sätt i 2 nya AAA-batterier i batterifacket. Se till att batteriernas + och - poler överensstämmer med diagrammet i batterifacket.
- 3 Sätt tillbaka batteriluckan. Dra inte åt skruven för hårt.

För bästa möjliga prestanda

- Använd endast de rekommenderade/medföljande batterierna eller motsvarande.
- Använd alkaliska batterier för längre livslängd.
- Blanda inte gamla och nya batterier, och blanda inte alkaliska, kol-zink eller laddningsbara nickel-kadmiumbatterier.
- Sätt i batterierna med rätt polaritet (+/-) såsom anges.
- Ta ut batterierna ur produkten när de är urladdade.
- Laddningsbara batterier ska laddas under en vuxens överinseende.
- Försök inte att ladda om icke-laddningsbara batterier.
- Öppna inte batterierna och värm inte upp dem över normal omgivningstemperatur.
- För att förhindra att batterierna läcker eller skadas, ta ut batterierna ur produkten om den inte används på en månad eller längre.
- Var mycket försiktig när du hanterar läckande batterier (undvik kontakt med ögon och hud). Om batterivätska kommer i kontakt med ögonen, skölj OMEDELBART med ljummet långsamt rinnande vatten i minst 30 minuter. Om den kommer i kontakt med huden, skölj med rent vatten i minst 15 minuter. Sök medicinsk vård om några symtom uppstår.
- Förvara på en sval, torr och ventilerad plats på avstånd från skadliga eller lättantändliga material.
- Kasta inte batterierna i hushållsavfall eller eld.
- Följ gällande lagar och lokala regler för kassering och transport av batterier.
- Batterier måste kastas separat på din lokala återvinningsstation. Kasta dem inte tillsammans med ditt hushållsavfall.
- Uppladdningsbara batterier ska plockas bort från leksaken innan de laddas.
- Anslutningskontaktterna ska inte kortslutas.

Att leka med Walkie Talkies

Walkie Talkies kan användas för många typer av roliga lekar och aktiviteter. Här kommer två förslag:

Kurragömma

Precis som vanlig kurragömma, fast med en skillnad: "Gömmaren" kan skicka ledtrådar till "Sökaren" via Walkie Talkies.

Mystiska ljud

Känner du igen det mystiska ljudet? Ett barn skickar ett ljud via sin Walkie Talkie, medan den andra försöker gissa vilket ljud det är. Det kan till exempel vara ett djur, en sång, en TV-show eller något annat!

Installera batterier

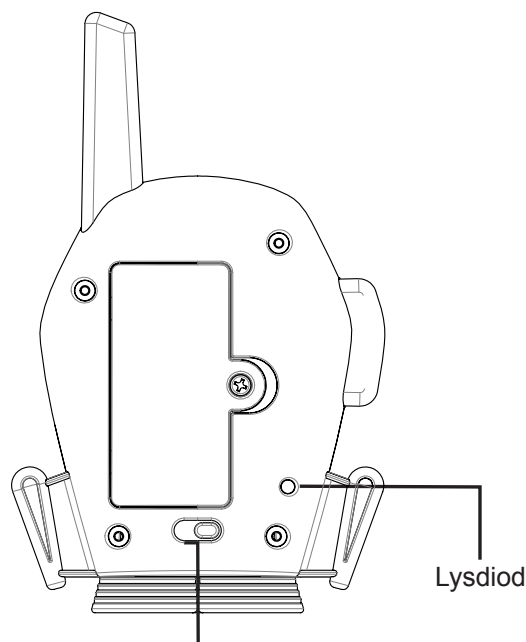

Knappen
ON/OFF (PÅ/AV)

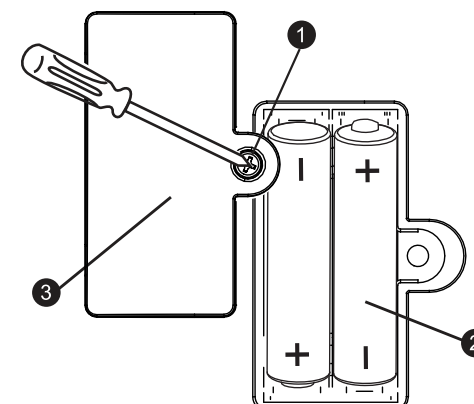

Antenn

Knappen Talk



Mikrofon/
högtalare

Slå PÅ/AV strömmen

- Skjut knappen ON/OFF till ON (PÅ) för att aktivera Walkie-Talkies. Strömdioden får ett fast sken.
- Skjut knappen ON/OFF till OFF (AV) för att slå av Walkie-Talkies. Strömdioden släcks.
- Båda Walkie-Talkies måste slås på för att kunna skicka och ta emot meddelanden.

Skicka röstmeddelanden

Håll inne knappen Talk när du talar i mikrofonen/högtalaren.

Bra att veta

För tydlig överföring, håll mikrofonen ca 5 cm från munnen.

Mottagande av meddelanden

- Båda Walkie Talkies måste vara påslagna för att ni ska kunna skicka och ta emot meddelanden.
- Meddelanden kan inte tas emot medan du trycker på knappen Talk.
- Meddelanden kan höras via mikrofonen/högtalaren.

Skötsel

Det är viktigt att dina Walkie Talkies är så torra och rena som möjligt. Du kan rengöra utsidan med en trasa eller fuktad svamp med mild tvål och vatten. Använd inte slipande rengöringsmedel eller lösningsmedel då den kan skada enheten.

Felsökning

Om en eller båda Walkie Talkies inte fungerar kan det bero på att batterierna är svaga. Sätt i 4 st nya AAA-batterier i respektive enhet.

Om signalområdet för en eller båda Walkie Talkies minskar avsevärt, kan det bero på att batterierna är svaga. Sätt i 4 st nya AAA-batterier i respektive enhet.

Kom ihåg att denna produkt inte har bra sändning vid hinder som träd, byggnader och metallkonstruktioner. Känner du av en stor statisk ökning, kan det bero på närheten av elmotorer, lysrör, kraftledningar eller andra signalstörande föremål. Ni kanske behöver byta till annan plats.

FÖRSÖK INTE REPARERA ENHETEN om problemet kvarstår. Se garantin för fabriksservice.

Model: TS-202

WALKIE TALKIES

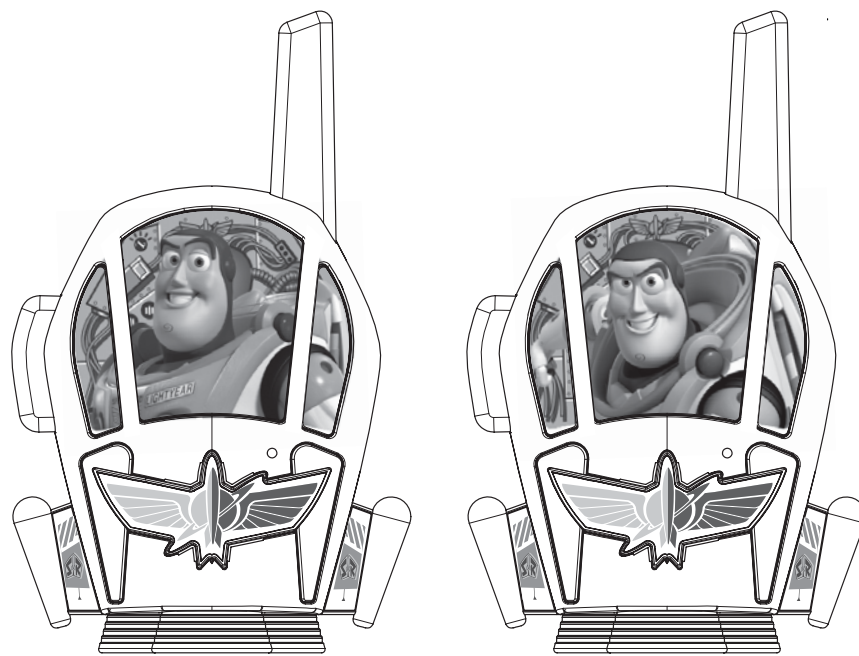

Frequency: 434MHz This product bears the selective sorting symbol for waste electrical and electronic equipment (WEEE). This means that this product must be handled pursuant to European Directive 2012/19/EU in order to be recycled or dismantled to minimize its impact on the environment. For further information, please contact your local or regional authorities. Electronic products not included in the selective sorting process are potentially dangerous for the environment and human health due to the presence of hazardous substances We, eKids declare that this device complies with the essential requirements of the RED Directive 2014/53/EU. This device complies with the essential requirements of the RED Directive 2014/53/EU. The following test methods have been applied in order to prove presumption of conformity with the essential requirements of the RED Directive 2014/53/EU

DK

UK
CA



CE

Kom godt i gang

De batterijen plaatsn

Bemærk: Batterier bør altid lægges i af en voksen.

- 1 Gebruik een Phillips schroevendraaier, open het batterijvak aan de achterkant van het apparaat.
- 2 Plaats drie nieuwe AAA-batterijen in het batterijvak. Zorg ervoor dat de batterijen overeenkomen met de + en - zoals aangeduid in het diagram van het batterijvak.
- 3 Plaats de klep van het batterijvak terug. Schroef de schroeven niet te vast.

Sådan får du den bedst mulige ydelse

- Brug kun anbefalede/medfølgende batterier eller tilsvarende.
- Brug alkalinebatterier for længere levetid.
- Undlad at blande gamle og nye batterier og sæt ikke alkaliske, kulstof-zink eller genopladelige nikkel-kadmium-batterier sammen.
- Sæt batterier i med den korrekte polaritet (+/-), som angivet.
- Fjern opbrugte batterier fra produktet.
- Genoplad genopladelige batterier under opsyn af en voksen.
- Batterier, der ikke er genopladelige, må ikke oplades.
- Batterier må ikke åbnes eller opvarmes til over normal omgivelsestemperatur.
- Tag batterier ud af produktet, hvis det ikke skal anvendes i en måned eller længere, for at forhindre batterilækage eller beskadigelse.
- Vær meget forsigtig ved håndtering af batterier med lækage (undgå direkte kontakt med øjne og hud). Hvis lækage fra et batteri kommer i kontakt med et øje, skal dette STRAKS skylles med lunkenet og stille flydende vand i mindst 30 minutter. Hvis der er kontakt med huden, skal denne vaskes med rent vand i mindst 15 minutter. Kontakt din læge, hvis der opstår evt. symptomer.
- Opbevar på et køligt, tørt og ventileret område og væk fra farlige eller brændbare materialer.
- Batterier må ikke bortskaffes med husholdningsaffald eller afbrændes.
- Følg relevant lovgivning og lokale regelsæt for bortskaffelse og transport af batterier.
- Batterier skal bortskaffes separat på dit lokale genbrugscenter. De må ikke bortskaffes sammen med dit husholdningsaffald.
- Genopladelige batterier skal ikke tages ud af legetøjet inden opladning.
- Forsyningsterminalerne må ikke kortsluttes.

Leg og spil med Walkie-Talkie

Walkie-Talkies kan anvendes til alle mulige sjove lege og aktiviteter. Her er to forslag:

Skjul

Ligesom almindelig skjul, men med en ekstra tilføjelse: "Den skjulte" kan sende tips til "Den søgende" ved hjælp af Walkie-Talkierne.

Mystiske lyde

Kan du genkende den mystiske lyd? Det ene barn sender en lyd via Walkie-Talkien, mens det andet prøver at gætte, hvad lyden er. Det kan fx være et dyr, en sang, et TV-show eller noget helt andet!

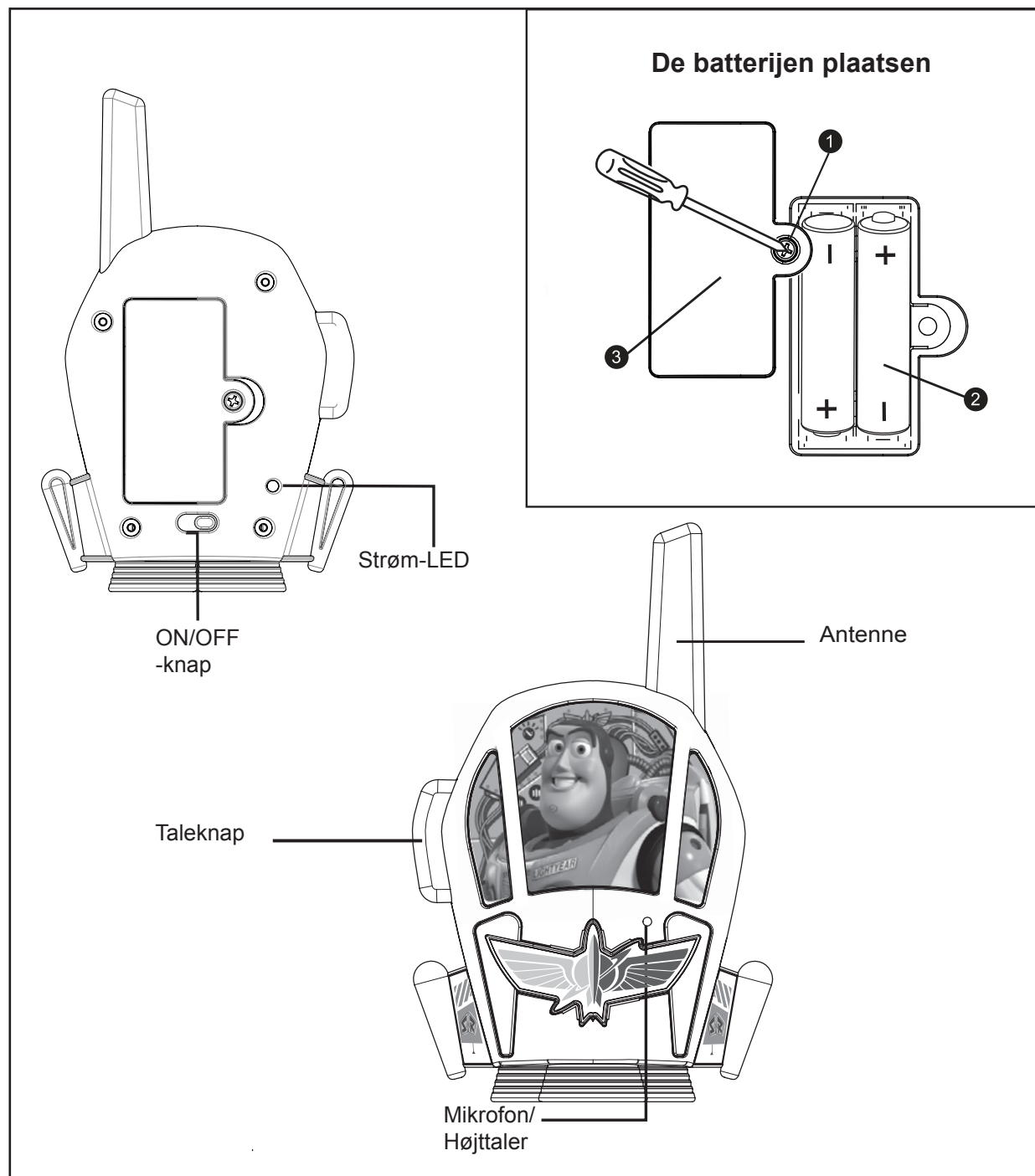

Tænde og slukke

- Skub ON/OFF-knappen over på ON for at tænde walkie-talkierne. LED strømindikatoren lyser konstant.
- Skub ON/OFF-knappen over på OFF for at slukke walkie-talkierne. LED strømindikatoren slukker.
- Begge walkie-talkier skal være tændt for at kunne sende og modtage beskeder.

Sende talebeskeder

Tryk og hold Taleknappen, mens du taler ind i mikrofonen/højttaleren.

Vær opmærksom på følgende

Du opnår den bedste forbindelse, hvis du holder mikrofonen ca. 5 cm fra munden.

Modtage beskeder

- Begge Walkie-Talkies skal være tændt for at du kan sende og modtage beskeder.
- Du kan ikke modtage beskeder, mens du holder Taleknappen trykket ind.
- Beskeder kan høres gennem mikrofonen/højttaleren.

Vedligehold

Det er vigtigt at holde dine Walkie-Talkies så tørre og rene, som muligt. Du kan rengøre kassen med en klud eller svamp fugtet med lidt vand med mild sæbe. Du må ikke bruge stærke rengøringsmidler eller opløsningsmidler, da de kan beskadige enheden.

Fejlfinding

Hvis den ene eller begge Walkie-Talkies ikke fungerer, kan det betyde, at batterierne er brugt op. Sæt 2 nye AAA-batterier i hver enhed.

Hvis Walkie-Talkiernes rækkevidde indskrænkes markant, kan det ligeledes være tegn på, at batterierne er brugt op. Sæt 2 nye AAA-batterier i hver enhed.

Vær opmærksom på, at dette produkt ikke sender godt gennem forhindringer som fx træer, bygninger og metalkonstruktioner. Hvis der sker en markant stigning i mængden af statisk støj, kan det skyldes elmotorer, lysstofrør, strømførende ledninger eller andre genstande, der befinder sig i nærheden og påvirker signalet. Du bliver i så fald måske nødt til at skifte placering.

Hvis problemerne fortsætter, MÅ DU IKKE FORSØGE SELV AT REPARERE ENHEDEN. Se Garantibeviset for oplysninger om fabrikkens service.

Modell: TS-202

WALKIE-TALKIER

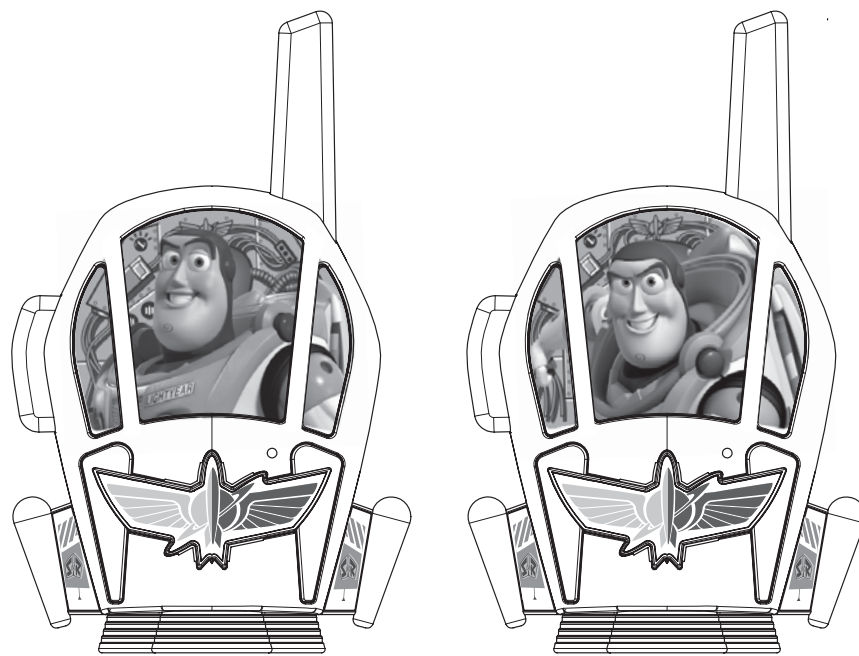

Frequency: 434MHz This product bears the selective sorting symbol for waste electrical and electronic equipment (WEEE). This means that this product must be handled pursuant to European Directive 2012/19/EU in order to be recycled or dismantled to minimize its impact on the environment. For further information, please contact your local or regional authorities. Electronic products not included in the selective sorting process are potentially dangerous for the environment and human health due to the presence of hazardous substances We, eKids declare that this device complies with the essential requirements of the RED Directive 2014/53/EU. This device complies with the essential requirements of the RED Directive 2014/53/EU. The following test methods have been applied in order to prove presumption of conformity with the essential requirements of the RED Directive 2014/53/EU

NO

UK
CA



CE

WALKIE-TALKIER

Sette inn batteriene

Merk: Batteriene skal kun betjenes av voksne.

- 1 Bruk en stjerneskrutrekker til å åpne batteriluken på baksiden av enheten.
- 2 Sett inn 2 nye AAA -batterier i batteriluken. Pass på at batteriene settes inn riktig vei, i henhold til pluss- og minustegnet som vises i batteriluken.
- 3 Sett batteriluken på plass igjen. Stram ikke skruen for mye.

Advarsler og tips for batteriet, sikkerhet og optimal ytelse

- Bruk bare anbefalte/medleverte batteriene eller tilsvarende.
- Bruk alkaliske batterier for lengre levetid.
- Bland ikke gamle og nye batterier, og bland ikke alkaliske, karbonsink eller oppladbare nikkeldadmium-batterier.
- Sett inn batteriene med riktig polaritet (+/-) som vist.
- Tomme batterier må tas ut av produktet.
- Oppladbare batterier må lades under oppsyn av en voksen.
- Prøv ikke å lade opp ikke-oppladbare batterier.
- Åpne ikke batterier og varm dem ikke opp til mer enn vanlig omgivelsestemperatur.
- For å unngå at batteriene begynner å lekke eller bli skadet, fjernes batteriene fra et produkt hvis det ikke skal brukes på en måned eller lengre.
- Vær svært forsiktig når du berører batterier (unngå direkte kontakt med øyne og hud). Hvis batterilekkasje kommer i kontakt med øyer, må du UMIDDELBART skylle øyet med lunke vann med lavt trykk, i minst 30 minutter. Hvis det oppstår hudkontakt, må huden vaskes med rent vann i minst 15 minutter. Oppsøk legehjelp dersom symptomer oppstår.
- Lagre på et kaldt, tørt og ventilert sted, på avstand fra farlige og brennbare materialer.
- Kast ikke batteriene i restavfall eller i flammer.
- Følg gjeldende lover og lokale vedtekter angående kasting og transport av batterier.
- Oppladbare batterier skal fjernes fra leken før lading.
- Strømterminalene må ikke kortsluttes.

Leke walkie talkie-leker

Walkie-talkier kan brukes til mange typer leker og morsomme aktiviteter. Her er to forslag:

Gjemsel

Akkurat som vanlig gjemsel, med en liten forbedring: Den som gjemmer seg kan bruke walkie-talkien til å sende hint til den som leter.

Mystiske lyder

Kjenner du igjen den mystiske lyden? En person sender lyder med walkie-talkien, mens den andre prøver å gjette hvilke lyder det er. Det kan for eksempel være dyrelyder, sanger, lyder fra TV-serier eller hva som helst annet.

Sette inn batteriene

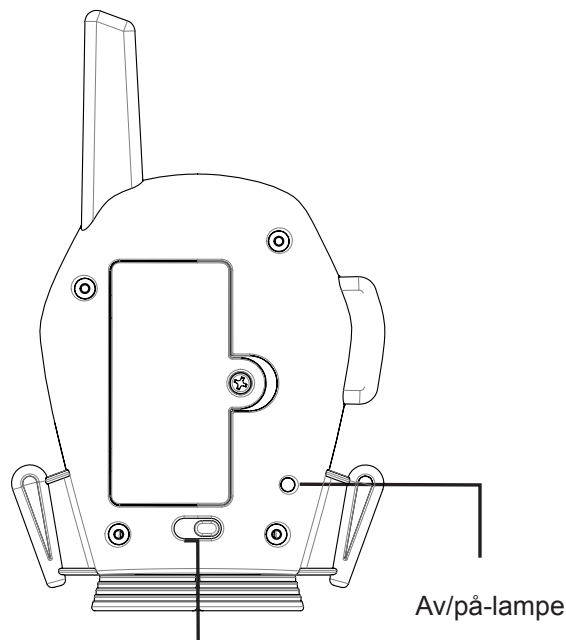
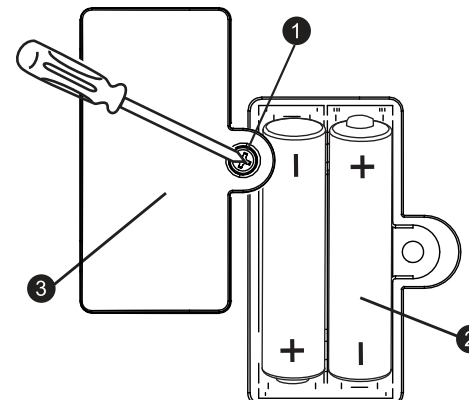

Av/på-knapp

Av/på-lampe

Antenne

Sendeknapp



Mikrofon
/høytaler

Skru av/på

- Skyv ON/OFF -knappen til ON for å aktivere walkie-talkiene. AV/PA-lampen lyser jevnt.
- Skyv ON/OFF -knappen til OFF for å skru av walkie-talkiene. AV/PA-lampen slukkes.
- Begge walkie-talkiene må være på for å sende og motta meldinger.

Sende talemeldinger

Hold inne sendeknappen og snakk inn i mikrofonen/høytaleren.

Husk:

Hold mikrofonen omtrent 5 cm fra munnen, så blir lyden mest tydelig.

Motta meldinger

- Begge walkie-talkiene må skrues på for å sende og motta meldinger.
- Det går ikke an å motta meldinger mens sendeknappen er trykket inn.
- Meldingene høres fra mikrofonen/høytaleren.

Vedlikehold

Det er viktig å holde walkie-talkiene så rene og tørre som mulig. Du kan rengjøre kabinettet med en klut eller svamp som er fuktet med mild såpe og vann. Bruk aldri sterke rengjøringsmidler eller løsemidler, da disse kan skade enheten.

Feilsøking

Hvis en av eller begge walkie-talkiene ikke fungerer, kan det bety at det er lite batteri. Sett inn fire nye AAA-batterier i hver av enhetene.

Hvis sendeavstanden til walkie-talkien synker betydelig, kan det bety at det er lite batteri. Sett inn fire nye AAA-batterier i hver av enhetene.

Husk at dette produktet ikke kan sende gode signaler gjennom hindringer som trær, bygninger og metallstrukturer. Hvis du opplever en merkbar økning i mengden statisk støy, kan det skyldes at du er for nærme en elektrisk motor, et lysstoffrør, strømlinjer eller andre signalforstyrrende elementer. Det kan hende du må flytte deg til et annet sted.

Hvis problemene vedvarer, må du IKKE prøve å reparere enheten selv. Les garantien for informasjon om fabrikk-tjenester.

Malli: TS-202

RADIOPUHELIMET

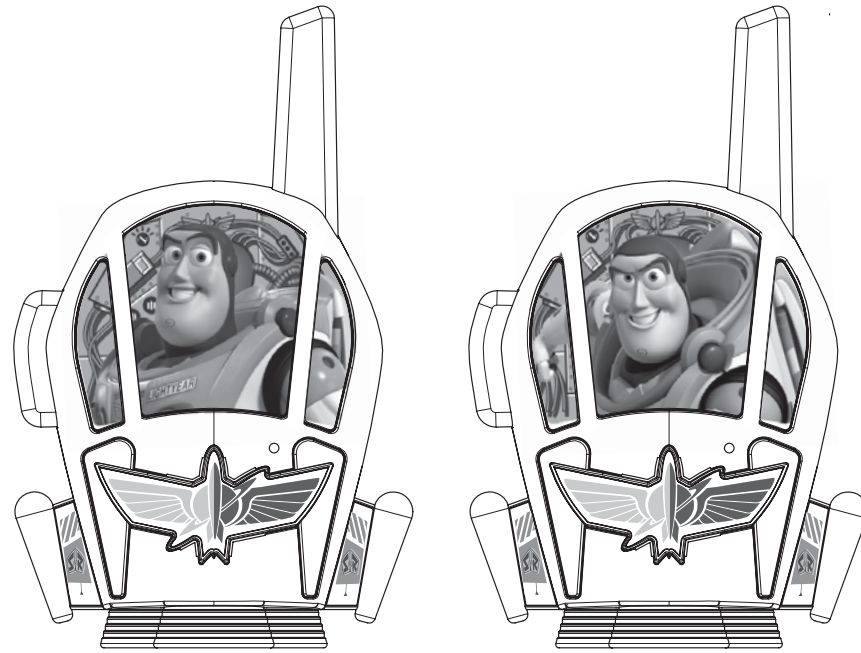

Frequency: 434MHz This product bears the selective sorting symbol for waste electrical and electronic equipment (WEEE). This means that this product must be handled pursuant to European Directive 2012/19/EU in order to be recycled or dismantled to minimize its impact on the environment. For further information, please contact your local or regional authorities. Electronic products not included in the selective sorting process are potentially dangerous for the environment and human health due to the presence of hazardous substances We, eKids declare that this device complies with the essential requirements of the RED Directive 2014/53/EU. This device complies with the essential requirements of the RED Directive 2014/53/EU. The following test methods have been applied in order to prove presumption of conformity with the essential requirements of the RED Directive 2014/53/EU



Aloituspas

Paristojen asettaminen

- Huomautus: Vain aikuinen saa asettaa paristot laitteeseen.
- 1 Avaa laitteen takana olevan paristolokeron kansi käyttäen ristipääruuvitaltaa.
 - 2 Aseta 2 uutta AAA-paristoa paristolokeroon. Varmista, että paristojen + ja - vastaavat paristolokeron merkintöjä.
 - 3 Sulje paristolokeron kansi. Älä ylikiristä ruuvia.

Paristojen käyttöä koskevat varoitukset ja turvallisuutta ja parasta suorituskykyä koskevat vinkit

- Käytä vain suositeltuja tai mukana toimitettuja paristoja tai niitä vastaavia.
- Käytä pidempään kestäviä alkaliparistoja.
- Älä sekoita keskenään uusia ja vanhoja paristoja tai alkaliparistoja, sinkki-hiiliparistoja ja ladattavia nikkeli-kadmium-akkuparistoja.
- Aseta paristot niin, että niiden navat (+/-) ovat kuvan osoittamalla tavalla.
- Poista tyhjät paristot tuotteesta.
- Lataa ladattavat akkuparistot aikuisen valvonnassa.
- Älä yritä ladata ei-ladattavia paristoja.
- Älä avaa paristoja tai lämmitä niitä tavallista ympäristön lämpötilaa kuumemmiksi.
- Estä paristojen vuotaminen tai vioittuminen poistamalla ne laitteesta, mikäli laitetta ei käytetä vähintään kuukauteen.
- Käsittele vuotavia paristoja erittäin varoen (vältä suoraa kosketusta silmien ja ihon kanssa). Jos paristosta vuotanut aine joutuu kosketuksiin silmän kanssa, huuhtelee silmää VALITTOMASTI haalealla ja kevyesti juoksevalla vedellä vähintään 30 minuutin ajan. Jos ainetta joutuu iholle, pese ihoa puhtaalla vedellä vähintään 15 minuutin ajan. Hakeudu lääkärin hoitoon, jos oireita ilmaantuu.
- Säilytä viileässä, kuivassa ja hyvin tuuletetussa paikassa kaukana vaarallisista tai tulenaroista aineista.
- Älä hävitä paristoja kotitalousjätteen mukana tai polttamalla.
- Noudata paristojen hävittämisessä ja kuljettamisessa sovellettavia paikallisia lakeja ja määräyksiä.
- Ladattavat paristot on poistettava lelusta ennen lataamista.
- Syöttöliittimiä ei saa oikosulkea.

Radiopuhelinleikkejä

Radiopuhelimia voidaan käyttää monenlaisiin hauskoihin peleihin ja leikkeihin. Tässä on kaksi ehdotusta:

Kuurupiilo

Aivan kuin tavallinen kuurupiilo, mutta pienellä muutoksella: piilossa olija voi antaa vinkkejä etsijälle radiopuhelimen välityksellä.

Mysteeriäännet

Tunnistatko mysteeriäännet? Yksi lapsi soittaa äänen radiopuhelimen kautta, ja toinen yrittää arvata, mikä ääni on kyseessä. Ääni voi olla esimerkiksi eläimen ääni, laulu, TV-sarjan ääni tai mikä tahansa muu!

Paristojen asettaminen

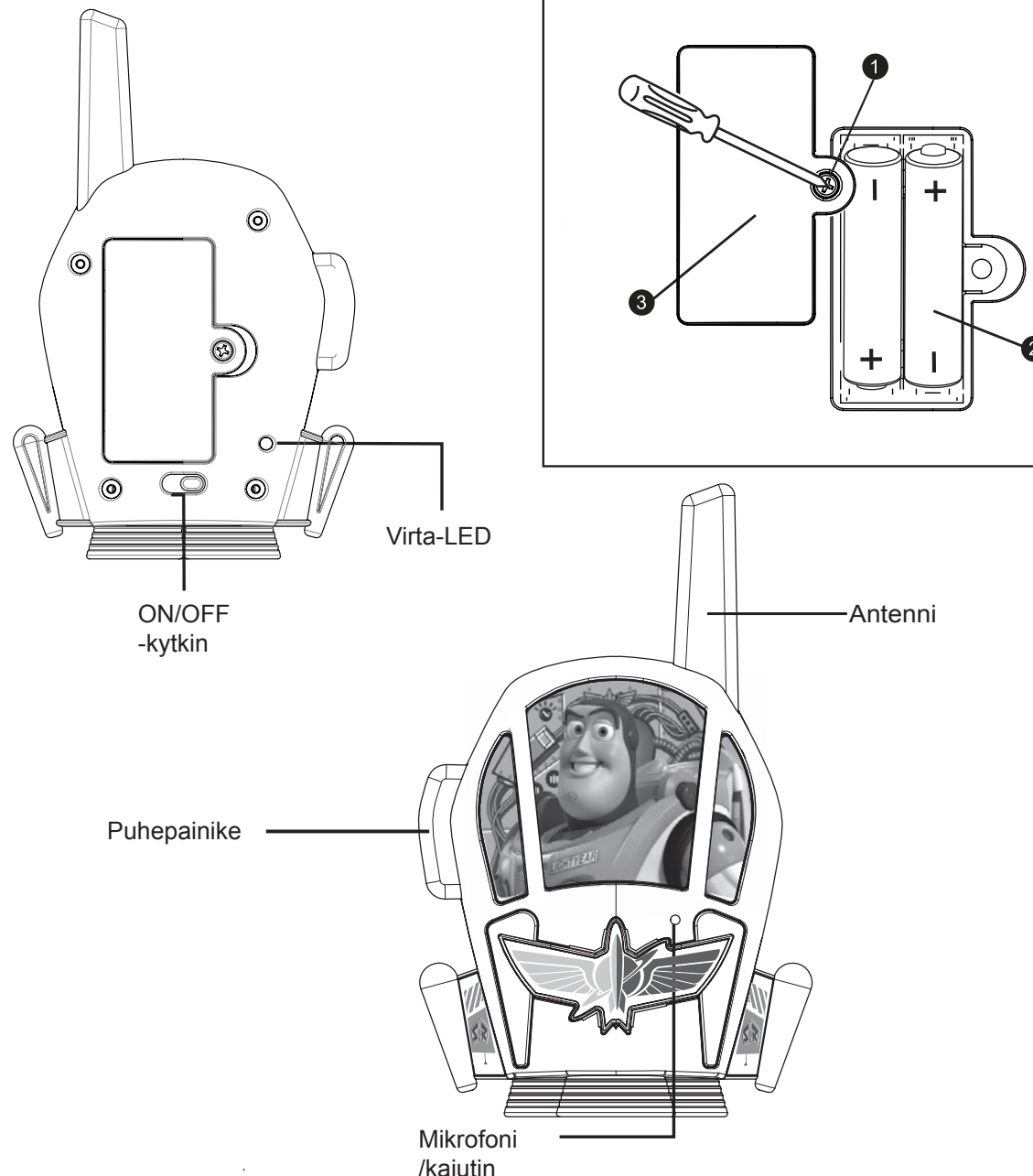

Virran kytkeminen päälle ja pois päältä

- Käynnistä radiopuhelimet liu'uttamalla ON/OFF -painike ON -asentoon. Virta-LED palaa kiinteästi.
- Sammuta radiopuhelimet liu'uttamalla ON/OFF -painike OFF -asentoon. Virta-LED sammuu.
- Molemmat radiopuhelimet on kytkettävä päälle, jotta viestejä voidaan lähettää tai vastaanottaa.

Ääniviestien lähettäminen

Pida puhepainiketta painettuna samalla, kun puhut mikrofoniin/kaiuttimeen.

Huomioitavaa

Varmista viestien selkeys pitämällä mikrofonia noin viiden senttimetrin päässä suustasi.

Viestien vastaanottaminen

- Kumpikin radiopuhelin pitää kytkeä päälle viestien lähettämistä ja vastaanottamista varten.
- Viestejä ei voida ottaa vastaan samaan aikaan, kun puhepainiketta painetaan.
- Viestit kuuluvat mikrofoniin/kaiuttimen kautta.

Huolto

Radiopuhelimet on tärkeää pitää mahdollisimman kuivina ja puhtaina. Voit puhdistaa kotelon miedolla saippuavedellä kostutetulla liinalla tai sienellä. Älä käytä voimakkaita puhdistusaineita tai liuottimia, sillä ne voivat aiheuttaa vaurioita.

Vianmääritys

Jos toinen tai kumpikaan radiopuhelin ei toimi, paristojen varaus voi olla vähissä. Aseta neljä uutta AAA-paristoa kumpaankin laitteeseen.

Myös radiopuhelimien kantaman merkittävä väheneminen voi olla merkki paristojen vähäisestä varaustasosta. Aseta neljä uutta AAA-paristoa kumpaankin laitteeseen. Pidä mielessä, että tuotteen signaali ei kulje hyvin puiden, rakennusten ja metallirakenteiden kaltaisten esteiden läpi. Kohinan merkittävä lisääntyminen voi johtua lähellä olevista sähkömoottoreista, loisteputkista, voimalinjoista tai muista signaalia häiritsevistä kohteista. Voit joutua siirtymään muualle. Mikäli ongelma jatkuu, ÄLÄ YRITÄ KORJATA LAITETTA ITSE. Katso tehdaspalvelut takuutiedoista.

EU Declaration of Conformity

Section 1	
Product	Disney Pixar Toy Story 4 WALKIE TALKIES
Model/type	TS-202.11X9Mi
Argos Cat. No.	8800790
Section 2	
Manufacturer Name & Address	KIDdesigns Inc. 1299, Main Street, Rahway, NJ 07065, U.S.A.
EU Authorised Representative	SGS Maco Customs Service Malledijk 18 NL-3208 LA Spijkenisse The Netherlands
Section 3	
This declaration is issued under the sole responsibility of the manufacturer.	
Section 4 Product Image	
Section 5	
<p>We hereby certify that the product stipulated above complies with all the relevant provisions of the following EC new approach directive/s (as amended):</p> <ul style="list-style-type: none"> • 2009/48/EC Toy Safety Directive • 2014/30/EU Electromagnetic Compatibility (EMC) • 2011/65/EU Restriction of Hazardous Substances (RoHS) • 2014/53/EU Radio Equipment Directive (RED) • 94/62/EC Packaging Directive • 2012/19/EU WEEE • 1907/2006 REACH Regulation (EC) 	

Section 6 & 7

Conformity is shown by compliance with the applicable requirements of the following harmonised standards:

Applicable Harmonized Standards (Standard reference, date and amendments) <i>e.g. EN 71-1:2014+A1:2018</i>	Notified Body (where applicable provide name, number and address of notified body) <i>e.g. Bureau Veritas Consumer Products Services – France; NB No.0406; rue John-Hadley BP 20431; 59658 Villeneuve d'Ascq Cedex</i>	Title <i>e.g. Safety of Toy: physical & mechanical</i>
EN71-1: 2014+A1:2018		Safety of Toy : physical & mechanical
EN71-2:2011+A1:2014		Safety of Toy: Flammability
EN71-3:2013+A3:2018		Safety of Toy: Migration of certain elements
EN62115		Safety of Electric Toys
ETSI EN 301 489-1 V2.2.3 : 2019 ETSI EN 301 489-17 V3.2.2:2019		Electromagnetic Compatibility (EMC) standard for radio equipment and services
ETSI EN 300 328 V2.2.2:2019		Wideband transmission systems; Data transmission equipment operating in the 2,4 GHz band; Harmonised Standard for access to radio spectrum
EN 62479:2010		Assessment of the compliance of low power electronic and electrical equipment with the basic restrictions related to human exposure to electromagnetic fields (10 MHz to 300 GHz)
EN 55032 : 2015 / A11 : 2020		Electromagnetic compatibility of multimedia equipment - Emission Requirements
EN55035:2017 / A11 : 2020		Electromagnetic compatibility of multimedia equipment - Immunity requirements
EN 61000-3-2 : 2019		Electromagnetic compatibility (EMC) - Part 3-2: Limits - Limits for harmonic current emissions (equipment input current ≤ 16 A per phase)
EN 61000-3-3 : 2013 +A1:2019		Electromagnetic compatibility (EMC) - Part 3-3: Limits - Limitation of voltage changes, voltage fluctuations and flicker in public low voltage supply systems, for equipment with rated current ≤ 16 A per phase and not subject to conditional connection

Section 8

Signed for and on behalf of:	KIDdesigns Inc.
Date of issue:	May 4, 2021
Name:	David Stetin
Position:	Product Safety and Compliance Officer
Signature:	

GB Declaration of Conformity

Section 1	
Product	Disney Princess WALKIE TALKIES
Model/type	DP-202
Argos Cat. No.	8800790
Section 2	
Manufacturer Name & Address	KIDdesigns Inc. P.O. Box 2228, Belfast, BT5 9GD
Section 3	
This declaration is issued under the sole responsibility of the manufacturer.	
Section 4 Product Image	
Section 5	
<p>We hereby certify that the product stipulated above complies with all the relevant provisions of the relevant UK legislation (as amended):</p> <ul style="list-style-type: none"> • Toys (Safety) Regulations 2011 • Electromagnetic Compatibility Regulations 2016 • Electrical Equipment (Safety) Regulations 2016 • The Restriction of the Use of Certain Hazardous Substances in Electrical and Electronic Equipment Regulations 2012 • Radio Equipment Regulations 2017 	
Section 6 & 7	
<p>Conformity is shown by compliance with the applicable requirements of the following designated standards:</p>	

Applicable Designated Standards (British Standard reference, date and amendments) <i>e.g. BS EN 71-1:2014+A1:2018</i>	Conformity Assessment Body (where applicable provide name, number and address of conformity assessment body) <i>e.g. Bureau Veritas UK Ltd; CAB No.2200; Warrington, UK</i>	Title <i>e.g. Safety of Toy: physical & mechanical</i>
BS EN71-1: 2014+A1:2018		Safety of Toy : physical & mechanical
BS EN71-2:2011+A1:2014		Safety of Toy: Flammability
EN71-3:2013+A3:2018		Safety of Toy: Migration of certain elements
EN62115 : 2020		Safety of Electric Toys
ETSI EN 301 489-1 V2.2.3 : 2019 ETSI EN 301 489-17 V3.2.2:2019		ElectroMagnetic Compatibility (EMC) standard for radio equipment and services
ETSI EN 300 328 V2.2.2:2019		Wideband transmission systems; Data transmission equipment operating in the 2,4 GHz band; Harmonised Standard for access to radio spectrum
BS EN 62479:2010		Assessment of the compliance of low power electronic and electrical equipment with the basic restrictions related to human exposure to electromagnetic fields (10 MHz to 300 GHz)
BS EN 55032 : 2015 / A11 : 2020		Electromagnetic compatibility of multimedia equipment - Emission Requirements
BS EN55035:2017 / A11 : 2020		Electromagnetic compatibility of multimedia equipment - Immunity requirements
BS EN 61000-3-2 : 2019		Electromagnetic compatibility (EMC) - Part 3-2: Limits - Limits for harmonic current emissions (equipment input current ≤ 16 A per phase)
BS EN 61000-3-3 : 2013 +A1:2019		Electromagnetic compatibility (EMC) - Part 3-3: Limits - Limitation of voltage changes, voltage fluctuations and flicker in public low voltage supply systems, for equipment with rated current ≤ 16 A per phase and not subject to conditional connection

Section 8

Signed for and on behalf of:	KIDdesigns Inc.
Date of issue:	May 4, 2021
Name:	David Stetin
Position:	Product Safety & Compliance Officer
Signature:	